

NOTES:
UNLESS SPECIFIED IN THE DRAWING,
ALL PRODUCTS DISPLAYED IN THIS
DRAWING OTHER THAN THE CASE
ITSELF IS NOT PART OF OUR PRODUCT
OFFERING.

PRODUCT FEATURES

CONSTRUCTION

- 12MM BIRCH VENEER PLYWOOD WITH HPL EXTERIOR FACE AND PVC INTERIOR FACE
- PENN ELCOM HARDWARE.
- 2X ERGONOMICALLY PLACED HANDLES FOR LIFTING AND TRANSPORTING
- MEDIUM LATCHES
- EVA38B FOAM PROTECTION
- 12MM PAIR CASTOR BOARD
- 4X 75MM CASTORS 2X BRAKED

FEATURES

- DEDICATED SPACE FOR KATANA HEAD MKII
- GENERAL STORAGE SPACE FOR ACCESSORIES
- EASY TO USE LIFT-OFF-LID DESIGN
- TRUCK-PACK FRIENDLY DESIGN

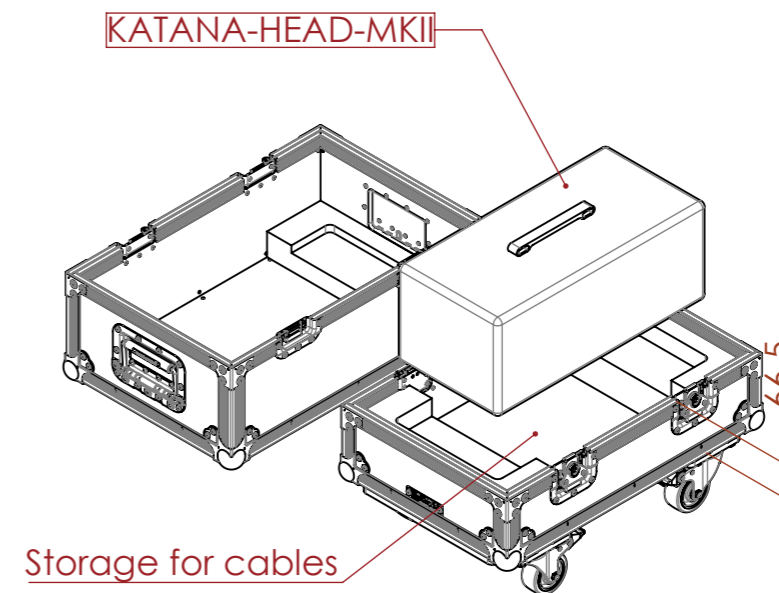
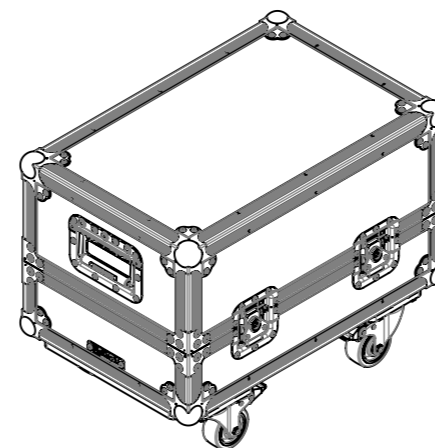

ESTIMATED WEIGHT (CASE ONLY):

17.1 KG

ITEM CODE:

AMP6435-BOSS-KHMKII

DRAWN BY:

H.A

CHECKED BY:

AS

SCALE:

NTS



MAIL : sales@armorcases.com.au
WEB : www.armorcases.com.au