

PRODUCT FEATURES

CONSTRUCTION

- 12MM BIRCH VENEER PLYWOOD WITH HPL EXTERIOR FACE AND PVC INTERIOR FACE
- PENN ELCOM HARDWARE

FEATURES

- TRUCK FRIENDLY SIZE
- 100MM STORAGE SPACE FOR CLAMPS AND ACCESSORIES
- CASTOR DISHES FOR STACKING CASES
- LABEL DISH FOR EASE OF RECOGNITION

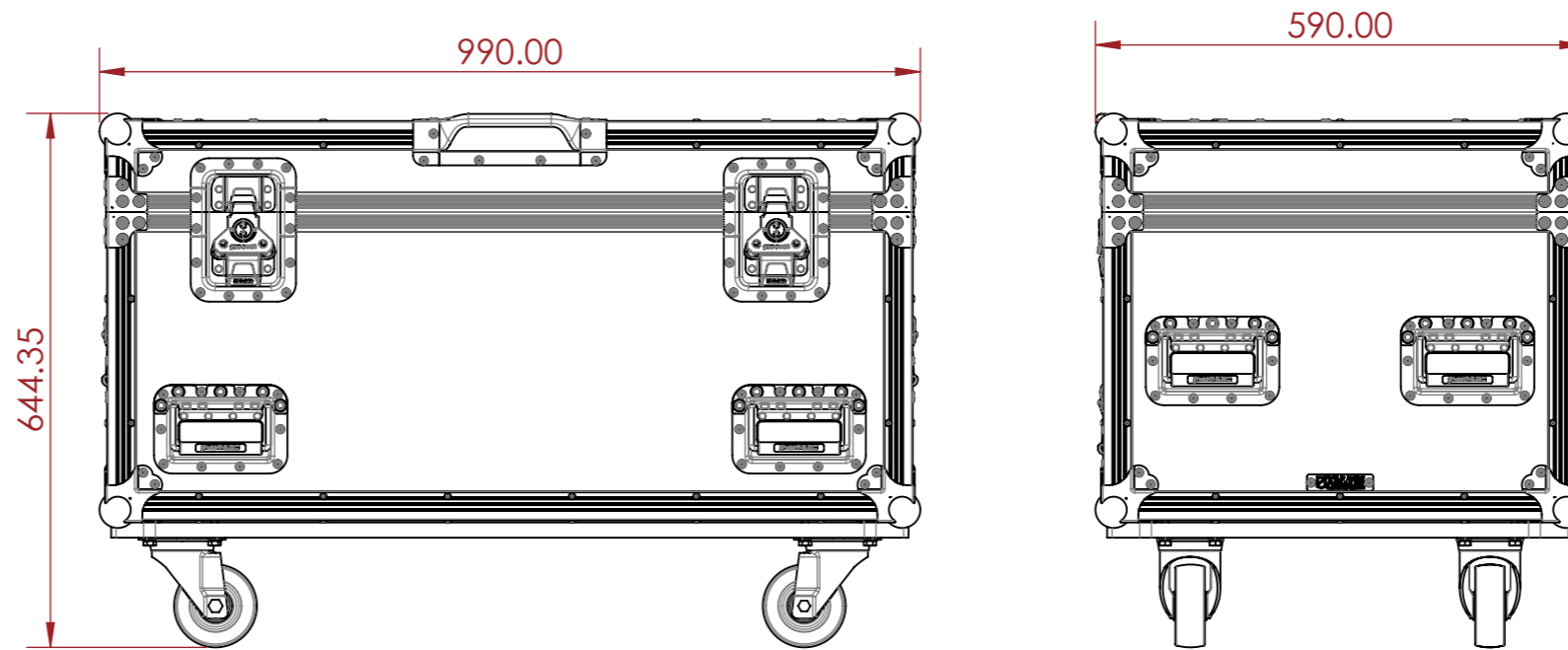

NOTES:

UNLESS SPECIFIED IN THE DRAWING, ALL PRODUCTS DISPLAYED IN THIS DRAWING OTHER THAN THE CASE ITSELF IS NOT PART OF OUR PRODUCT OFFERING.

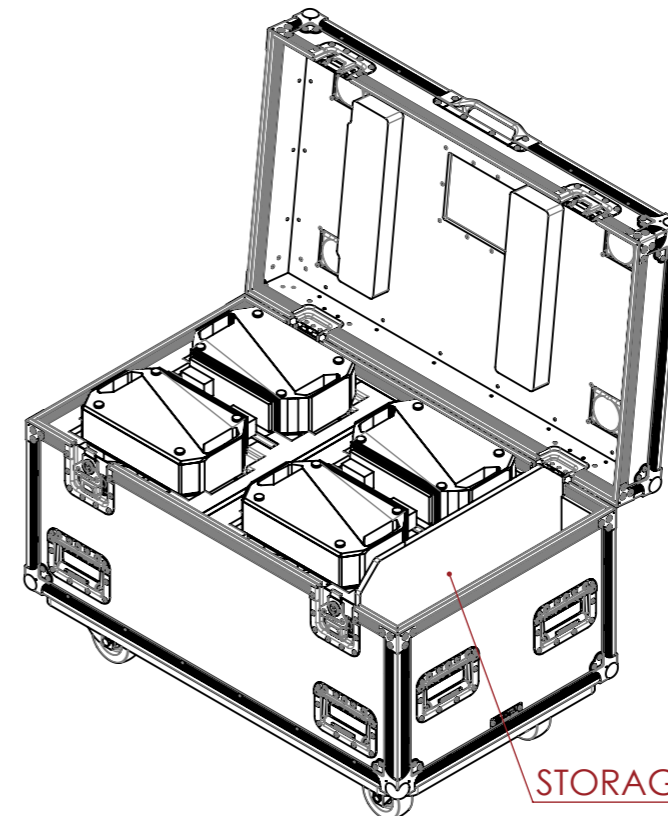

STORAGE SPACE

ESTIMATED WEIGHT (CASE ONLY):

52.00 KG

ITEM CODE:

LXMOV-MTN-AURAXIP

DRAWN BY:

KI

CHECKED BY:

AS

SCALE:

NTS



MAIL : sales@armorcases.com.au
WEB : www.armorcases.com.au