

PRODUCT FEATURES

CONSTRUCTION

- 12MM BIRCH VENEER PLYWOOD WITH HPL EXTERIOR FACE AND PVC INTERIOR FACE
- PENN ELCOM HARDWARE

FEATURES

- TRUCK FRIENDLY SIZE
- 180MM WIDE STORAGE SPACE FOR ACCESSORIES
- CASTOR DISHES FOR STACKING
- LABEL DISH FOR EASE OF IDENTIFICATION
- STORES 2X MARTIN QUANTUM PROFILE LIGHTS

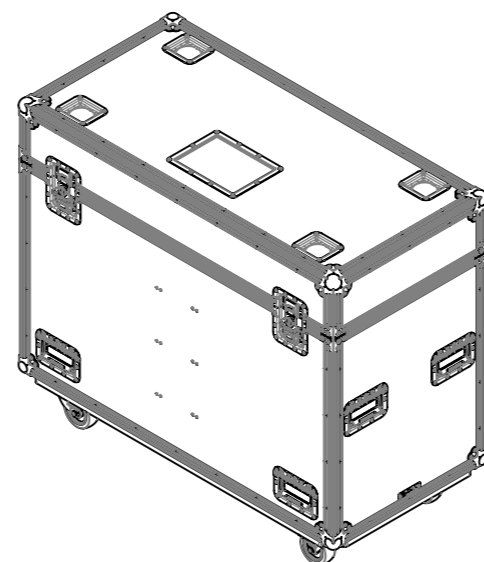
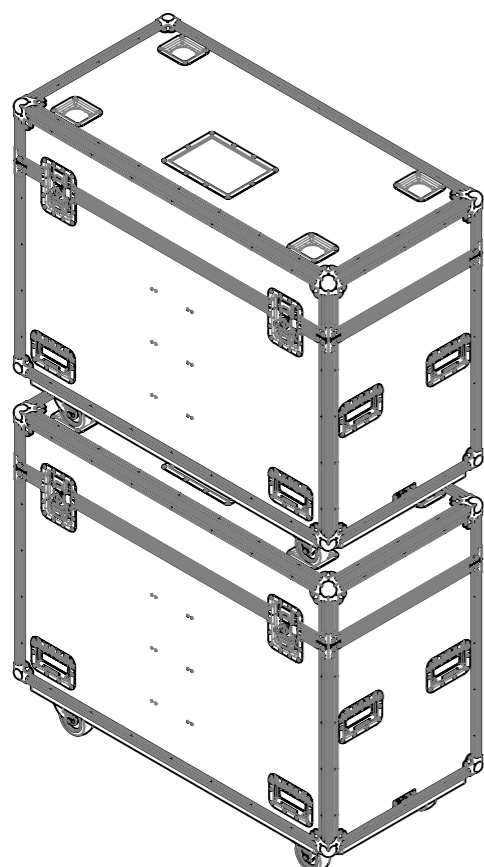
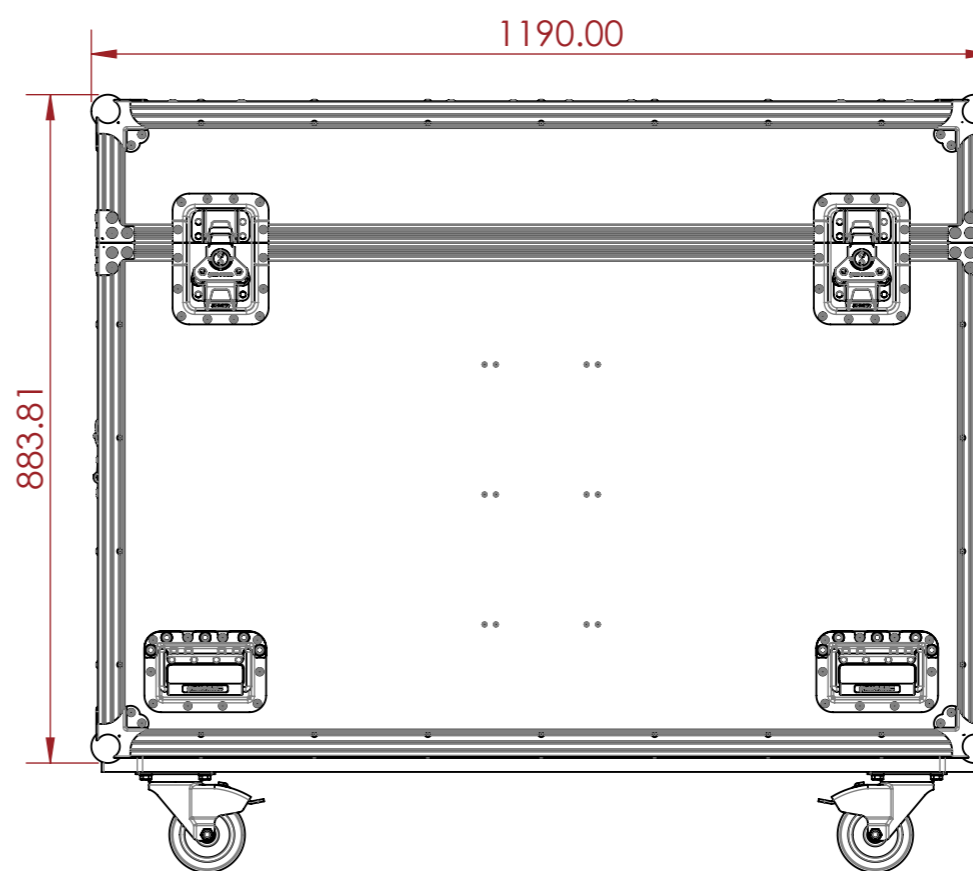
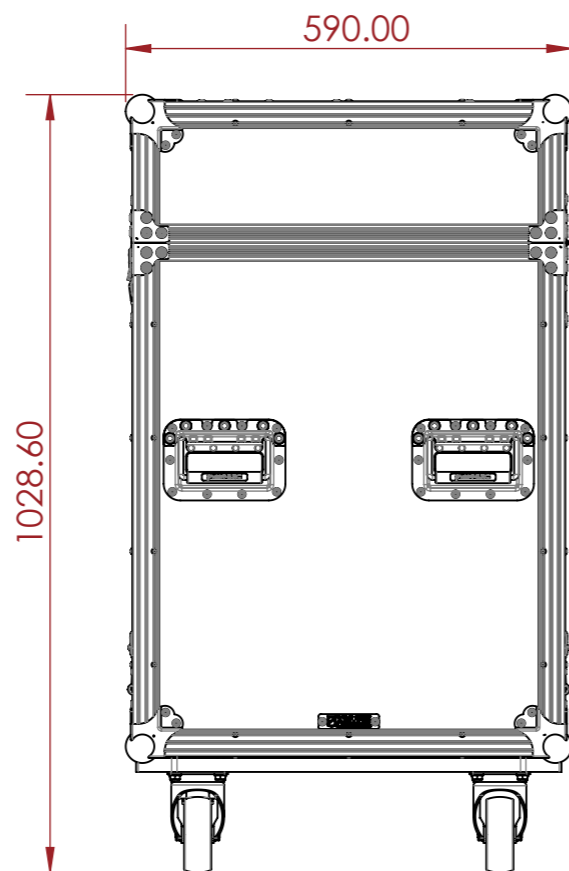

STORAGE SPACE

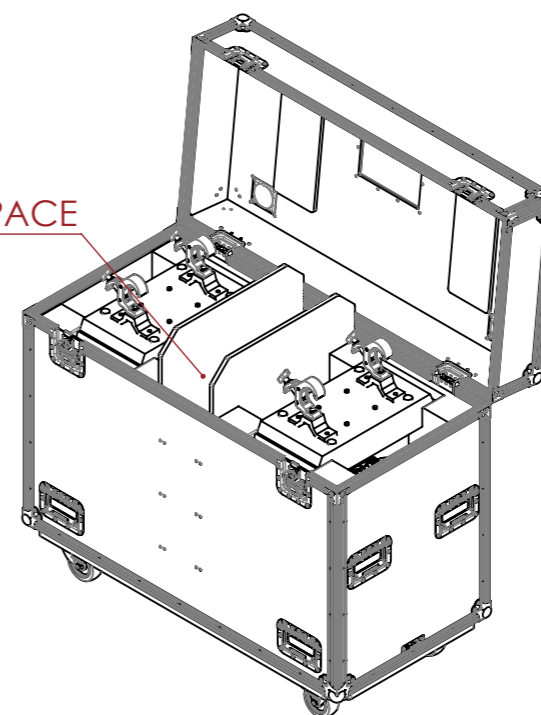

NOTES:
UNLESS SPECIFIED IN THE DRAWING,
ALL PRODUCTS DISPLAYED IN THIS
DRAWING OTHER THAN THE CASE
ITSELF IS NOT PART OF OUR PRODUCT
OFFERING.

ESTIMATED WEIGHT (CASE ONLY):

76.23 KG

ITEM CODE:

LXMH-MARTIN-QUANTUM

DRAWN BY:

K.I

CHECKED BY:

AS

SCALE:

NTS



MAIL : sales@armorcases.com.au
WEB : www.armorcases.com.au