

NOTES:
UNLESS SPECIFIED IN THE DRAWING,
ALL PRODUCTS DISPLAYED IN THIS
DRAWING OTHER THAN THE CASE
ITSELF IS NOT PART OF OUR PRODUCT
OFFERING.

PRODUCT FEATURES

CONSTRUCTION

- 7MM HIGH QUALITY PLASTIC PANEL
- 2X ERGONOMICALLY PLACED HANDLES FOR LIFTING AND TRANSPORTING
- 4X MEDIUM LATCHES
- EVA38 FOAM PROTECTION
- 2XCASTORS LOCATED FOR SUIT CASE STYLE MOBILITY
- FEET FOR EASE OF LAYING THE CASE ON THE GROUND FOR USE

FEATURES

- DEDICATED SPACE FOR LG-32SR50FW
- 0-45 DEGREE ANGLE ADJUSTABLE PLATFORM FOR MONITOR USING RATCHET LIDSTAYS
- PATCH PANEL WITH 8X TYPE D CONNECTOR SLOTS
- COMPACT DESIGN

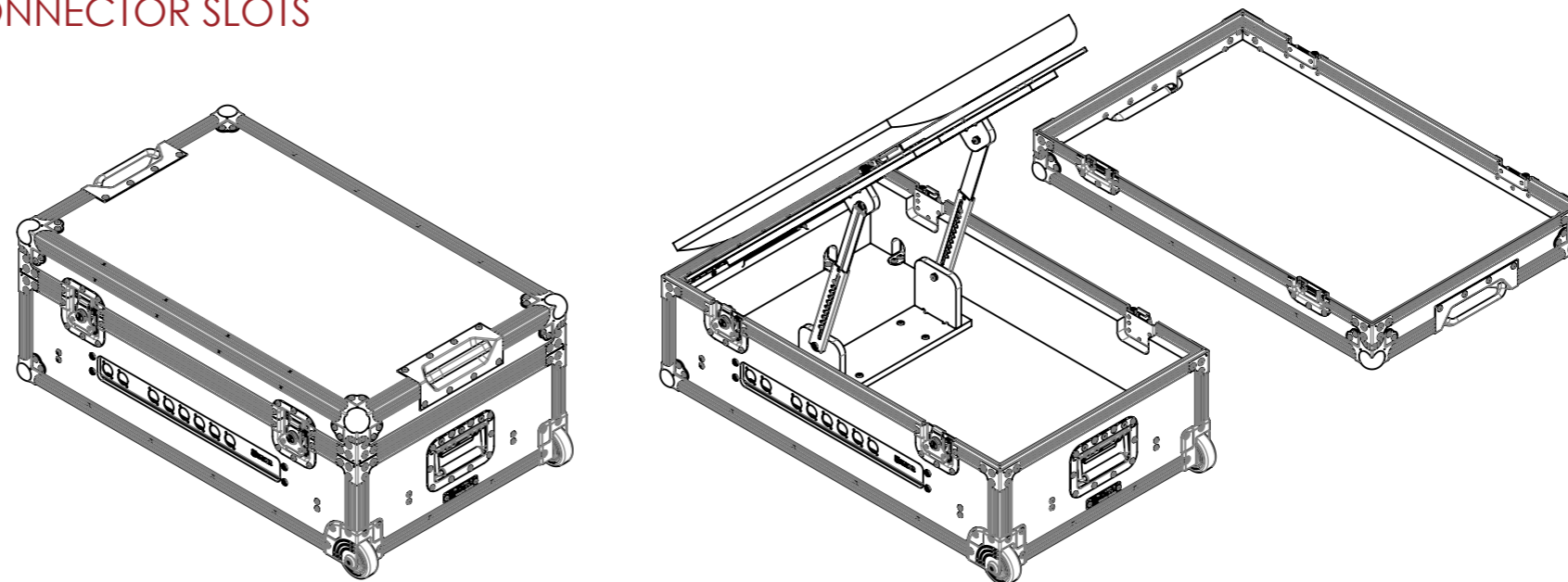

ESTIMATED WEIGHT (CASE ONLY):

17.38 KG

ITEM CODE:

DISP-SM-LG-32SR50FW

DRAWN BY:

HA

CHECKED BY:

AS

SCALE:

NTS



MAIL : sales@armorcases.com.au
WEB : www.armorcases.com.au