

PRODUCT FEATURES

CONSTRUCTION

- 12MM HIGH QUALITY PLYWOOD PANEL
- ALUMINIUM EXTRUSIONS
- STEEL BALL CORNERS
- EVA FOAM

FEATURES

- DEDICATED SPACE FOR CT11500 AND ADDITIONAL ACCESSORIES
- EASY TO LIFT LID

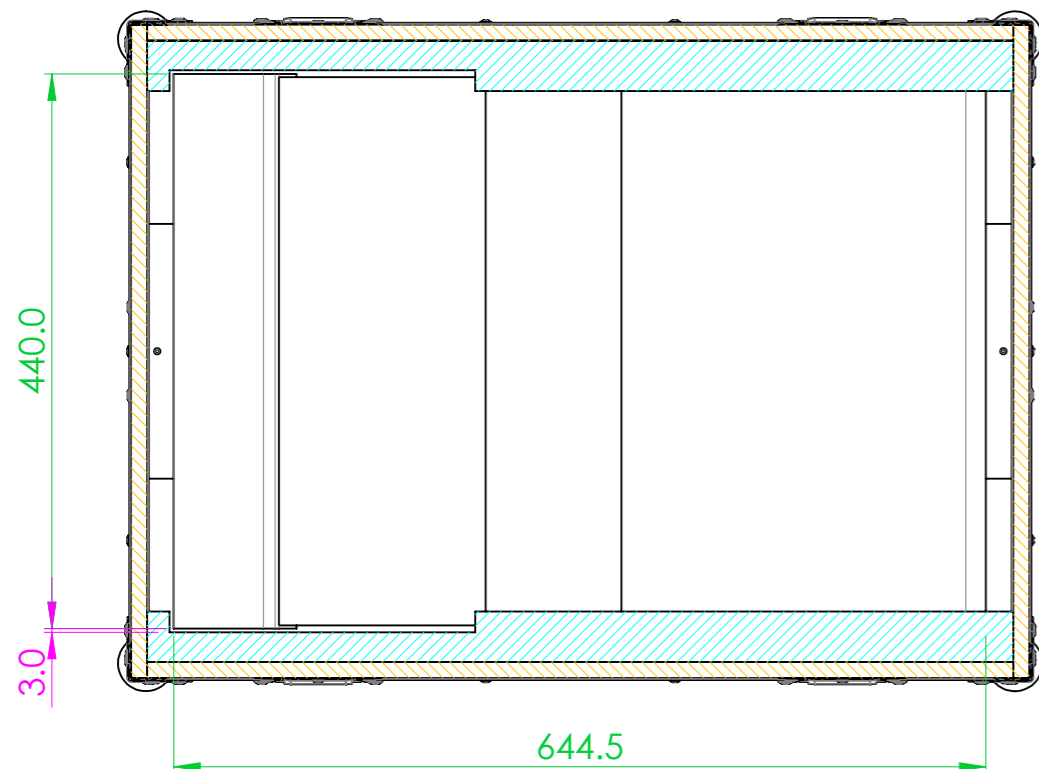

SECTION B-B
SCALE 1 : 6

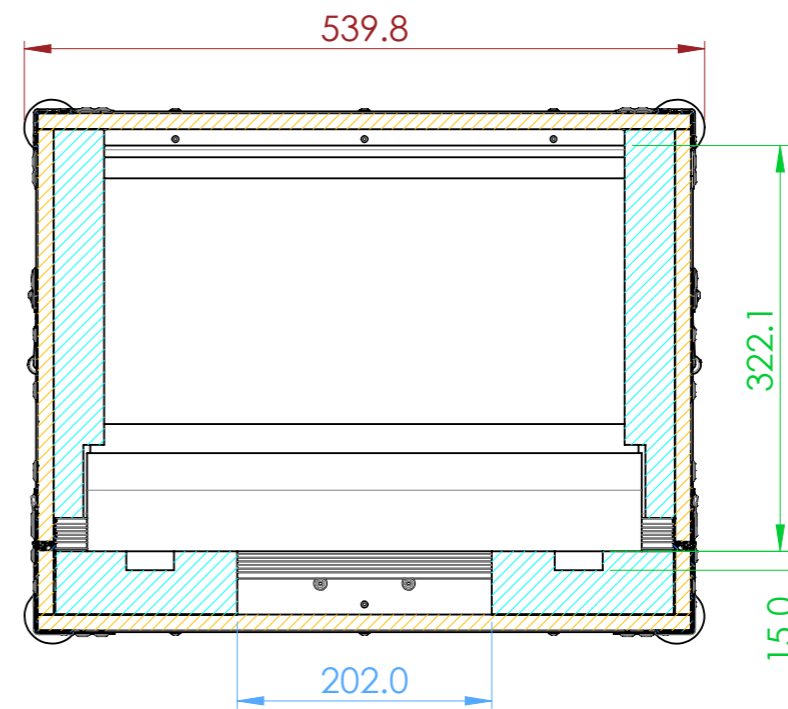

SECTION A-A
SCALE 1 : 6

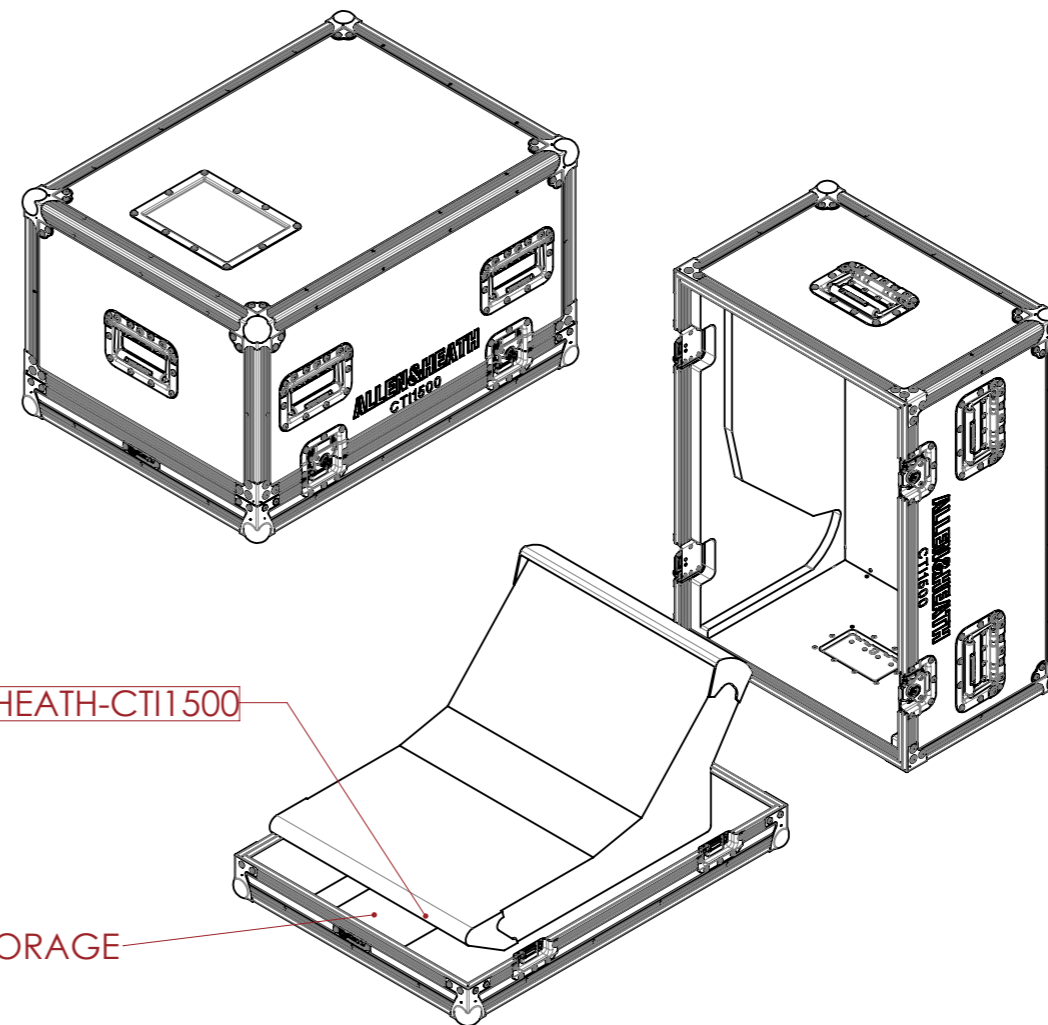

NOTES:
UNLESS SPECIFIED IN THE DRAWING,
ALL PRODUCTS DISPLAYED IN THIS
DRAWING OTHER THAN THE CASE
ITSELF IS NOT PART OF OUR PRODUCT
OFFERING.

ESTIMATED WEIGHT (CASE ONLY):

21.27 KG

ITEM CODE:

MIXR-AH-CT11500

DRAWN BY:

HA

CHECKED BY:

AS

SCALE:

NTS



MAIL : sales@armorcases.com.au
WEB : www.armorcases.com.au