

PRODUCT FEATURES

CONSTRUCTION

- 12MM HIGH QUALITY DOUBLE SIDED LAMINATED BIRCH PANEL
- PENN ELCOM HARDWARE

FEATURES

- STORAGE SPACE UNDERNEATH THE EQUIPMENT

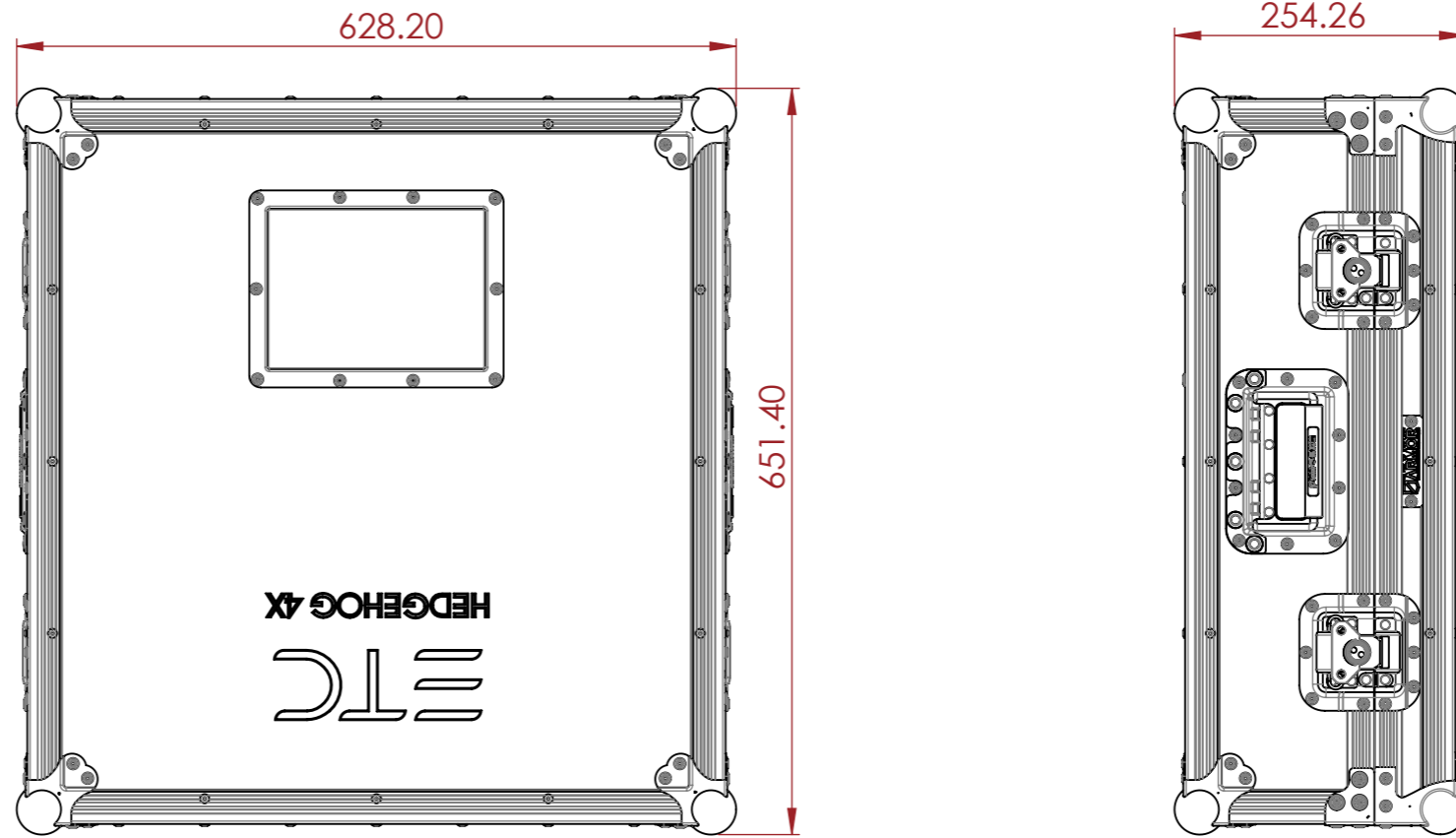

NOTES:
UNLESS SPECIFIED IN THE DRAWING,
ALL PRODUCTS DISPLAYED IN THIS
DRAWING OTHER THAN THE CASE
ITSELF IS NOT PART OF OUR PRODUCT
OFFERING.

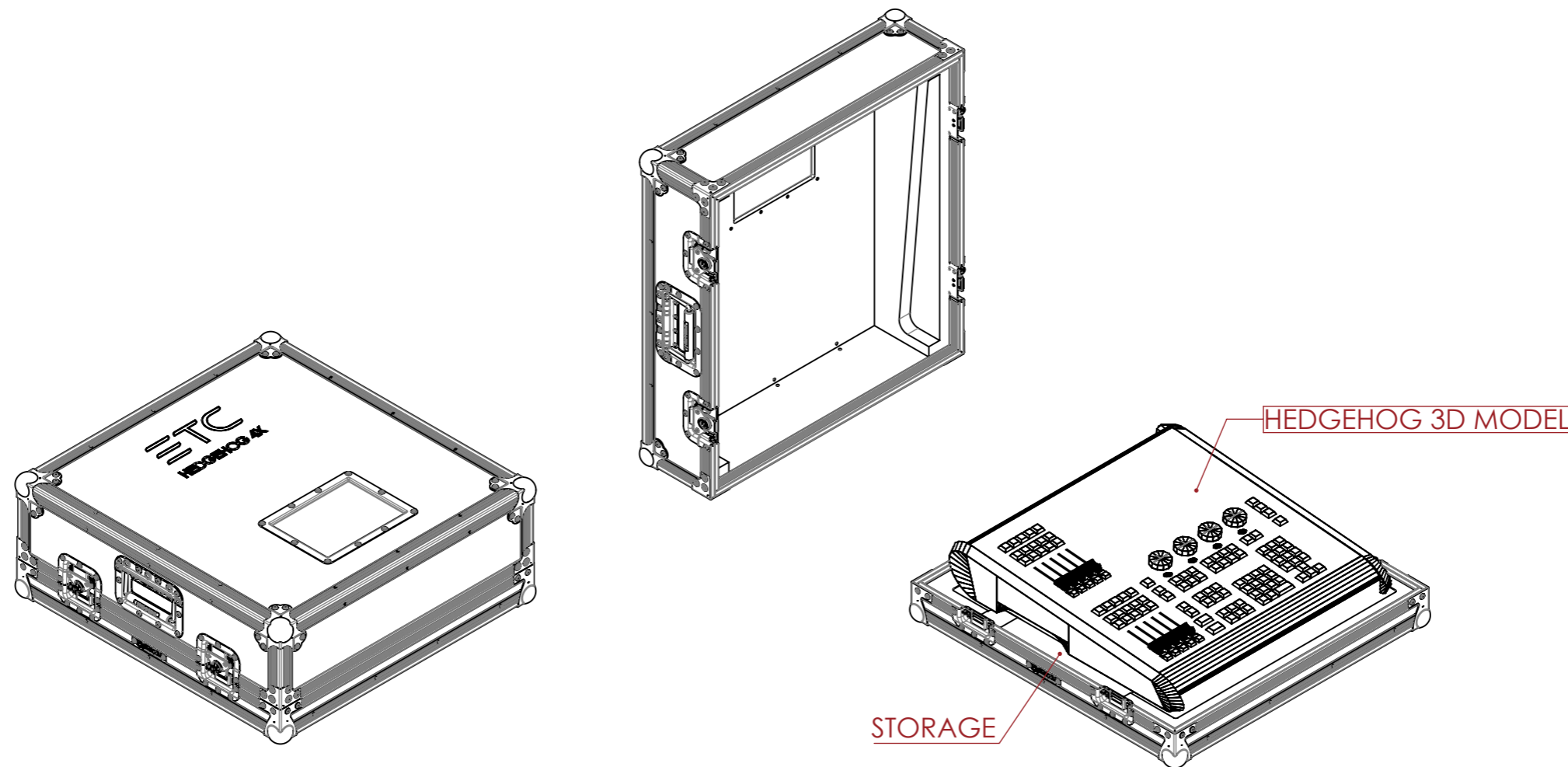

ESTIMATED WEIGHT (CASE ONLY):

15.99 KG

ITEM CODE:

LXCTRL-ETC-HH4X

DRAWN BY:

K.I

CHECKED BY:

AS

SCALE:

NTS



MAIL : sales@armorcases.com.au
WEB : www.armorcases.com.au