

## PRODUCT FEATURES

### CONSTRUCTION

- 12MM BIRCH VENEER PLYWOOD WITH HPL EXTERIOR FACE AND PVC INTERIOR FACE
- ARMOR HARDWARE

### FEATURES

- FRONT HINGED CASE FOR CARRYING TIMPANI LUDWIG 20"
- FOAM PADDING FOR PROTECTING THE EQUIPMENT

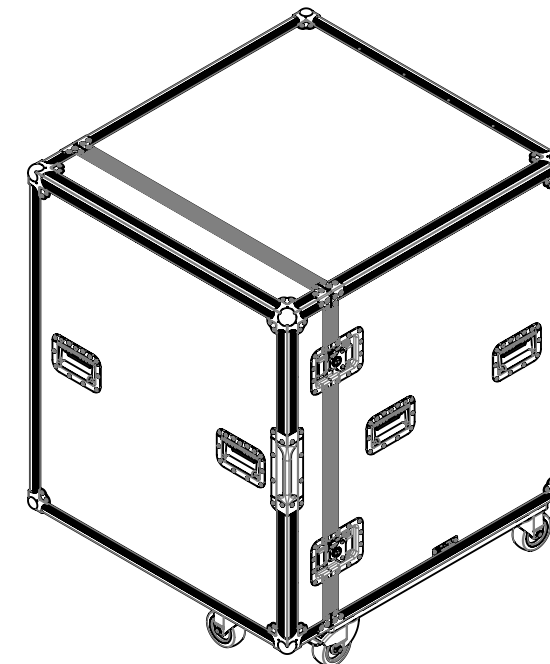
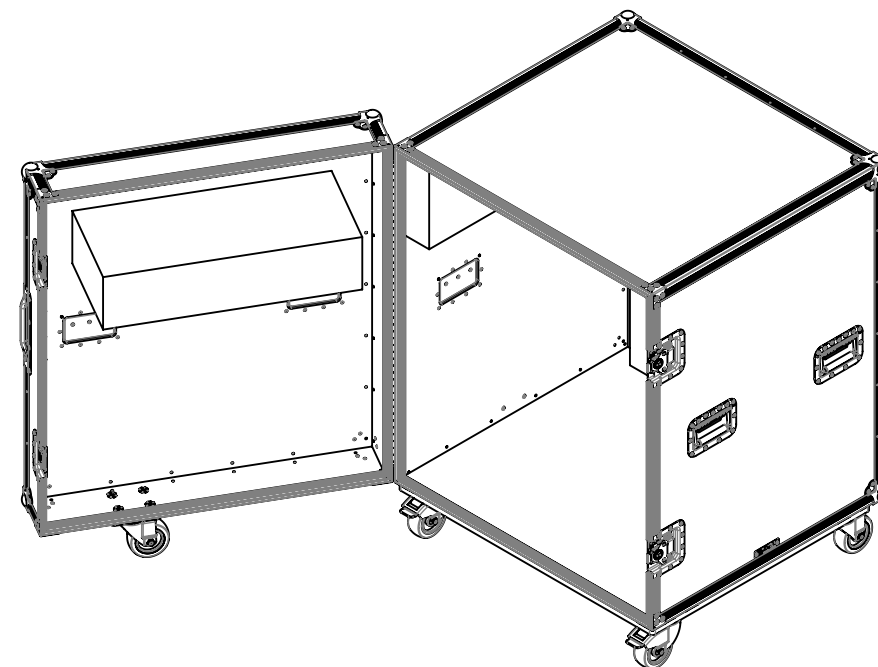
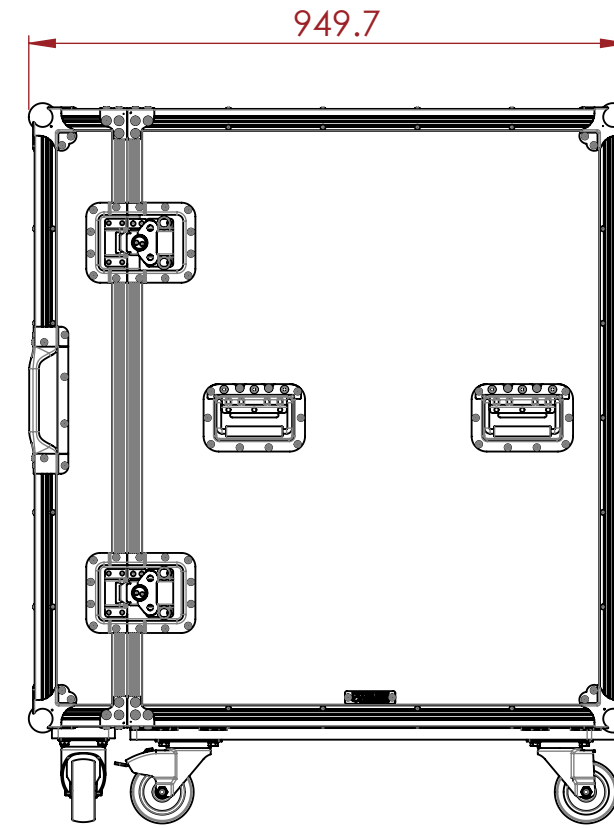
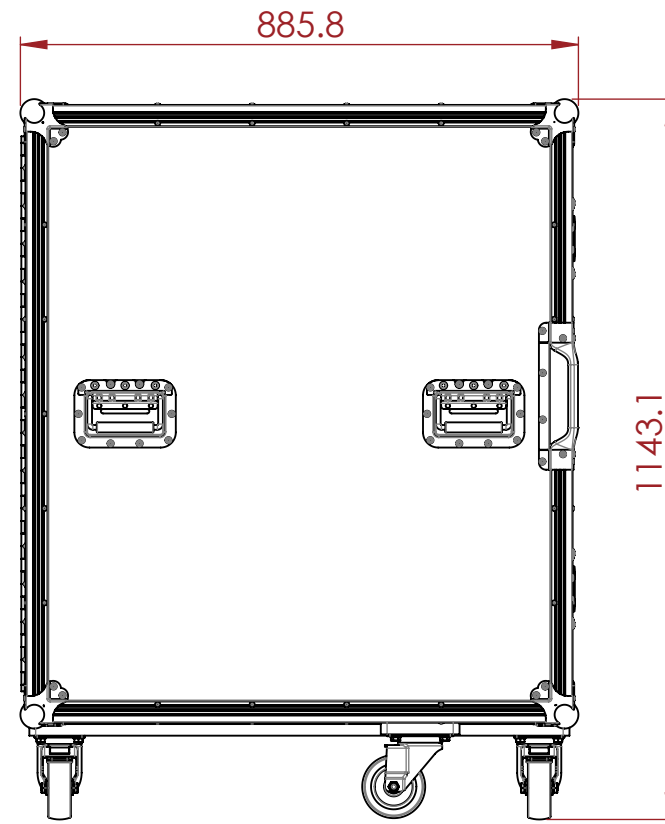

### NOTES:

UNLESS SPECIFIED IN THE DRAWING, ALL PRODUCTS DISPLAYED IN THIS DRAWING OTHER THAN THE CASE ITSELF IS NOT PART OF OUR PRODUCT OFFERING.

ESTIMATED WEIGHT (CASE ONLY):

71.21 KG

ITEM CODE:

FOL-LUDW-TP-P20-OP

DRAWN BY:

K.I

CHECKED BY:

AS

SCALE:

NTS



MAIL : [sales@armorcases.com.au](mailto:sales@armorcases.com.au)  
WEB : [www.armorcases.com.au](http://www.armorcases.com.au)