

PRODUCT FEATURES

CONSTRUCTION

- 12MM BIRCH VENEER PLYWOOD WITH HPL EXTERIOR FACE AND PVC INTERIOR FACE
- ARMOR HARDWARE

FEATURES

- FRONT HINGED CASE FOR CARRYING ADAMS PRO GEN2 29 INCH
- FOAM PADDING FOR PROTECTING THE EQUIPMENT
- RAMP TO ALLOW EASIER LOADING OF THE PRODUCT

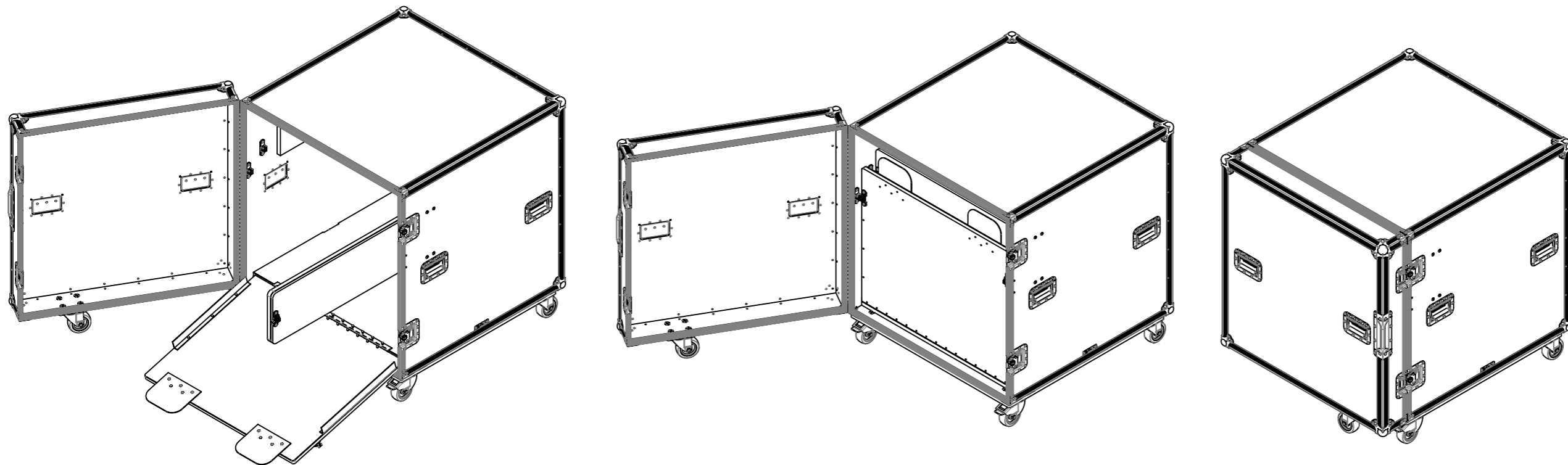
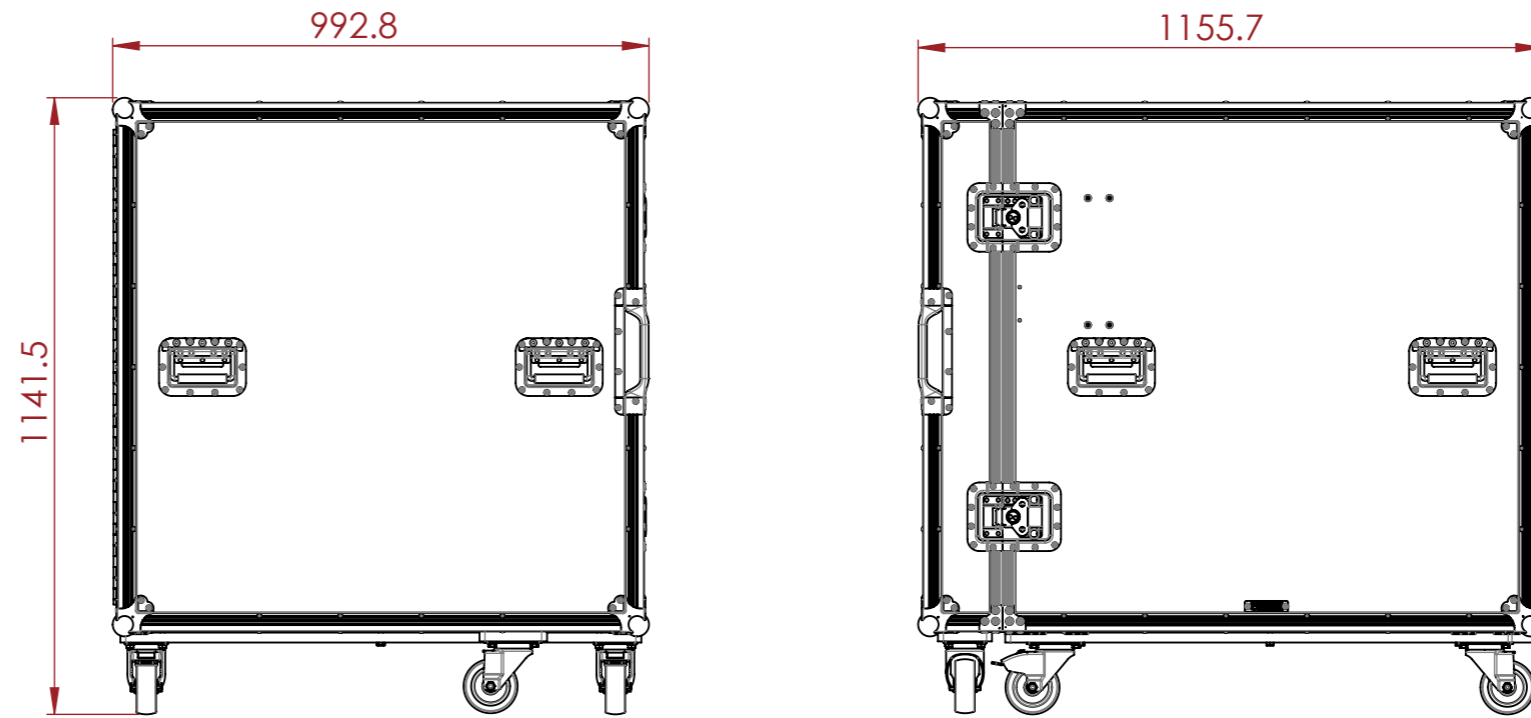

NOTES:
UNLESS SPECIFIED IN THE DRAWING,
ALL PRODUCTS DISPLAYED IN THIS
DRAWING OTHER THAN THE CASE
ITSELF IS NOT PART OF OUR PRODUCT
OFFERING.

ESTIMATED WEIGHT (CASE ONLY):

106.99 KG

ITEM CODE:

FOL-ADMS-TP-P229-OP

DRAWN BY:

K.I

CHECKED BY:

AS

SCALE:

NTS



MAIL : sales@armorcases.com.au
WEB : www.armorcases.com.au