

NOTES:
UNLESS SPECIFIED IN THE DRAWING,
ALL PRODUCTS DISPLAYED IN THIS
DRAWING OTHER THAN THE CASE
ITSELF IS NOT PART OF OUR PRODUCT
OFFERING.

PRODUCT FEATURES

CONSTRUCTION

- 12MM HIGH QUALITY PLYWOOD PANEL
- PENN ELCOM HARDWARE
- 2X ERGONOMICALLY PLACED HANDLES FOR LIFTING AND TRANSPORTING
- MEDIUM LATCHES
- EVA38B FOAM PROTECTION

FEATURES

- DEDICATED SPACE FOR 24 INCH-DELL P2418
- GENERAL PURPOSE STORAGE FOR ACCESSORIES.
- COMPACT DESIGN

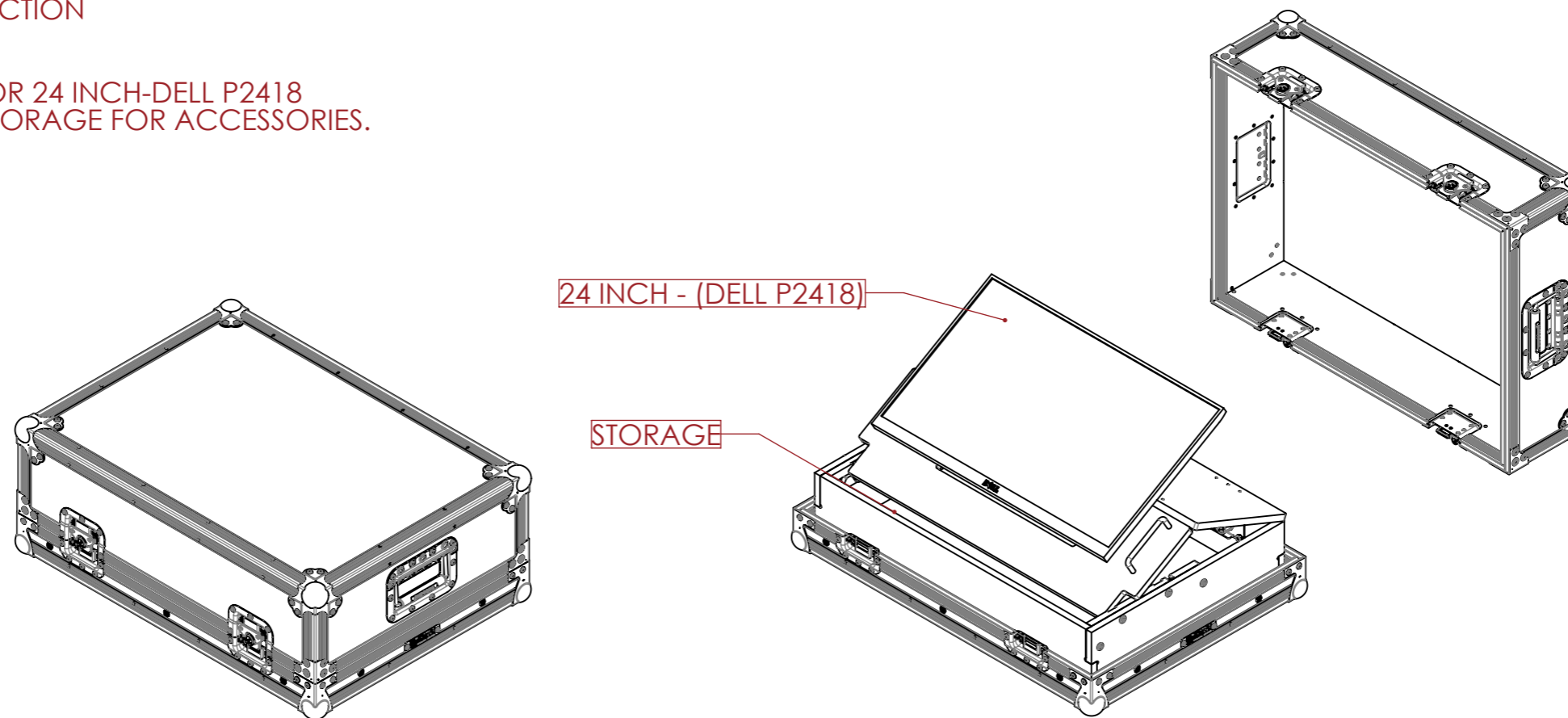

ESTIMATED WEIGHT (CASE ONLY):

19.7 KG

ITEM CODE:

DISP-TPTR-24

DRAWN BY:

H.A

CHECKED BY:

AS

SCALE:

NTS



MAIL : sales@armorcases.com.au
WEB : www.armorcases.com.au