

NOTES:  
UNLESS SPECIFIED IN THE DRAWING,  
ALL PRODUCTS DISPLAYED IN THIS  
DRAWING OTHER THAN THE CASE  
ITSELF IS NOT PART OF OUR PRODUCT  
OFFERING.

**PRODUCT FEATURES**

**CONSTRUCTION**

- 12MM BIRCH VENEER PLYWOOD WITH HPL EXTERIOR FACE AND PVC INTERIOR FACE
- PENN ELCOM HARDWARE.
- 2X ERGONOMIALLY PLACED HANDLES FOR LIFTING AND TRANSPORTING
- MEDIUM LATCHES
- EVA38B FOAM PROTECTION

**FEATURES**

- DEDICATED SPACE FOR YAMAHA HS8
- GENERAL STORAGE SPACE FOR ACCESSORIES
- EASY TO USE LIFT-OFF-LID DESIGN
- COMPACT DESIGN

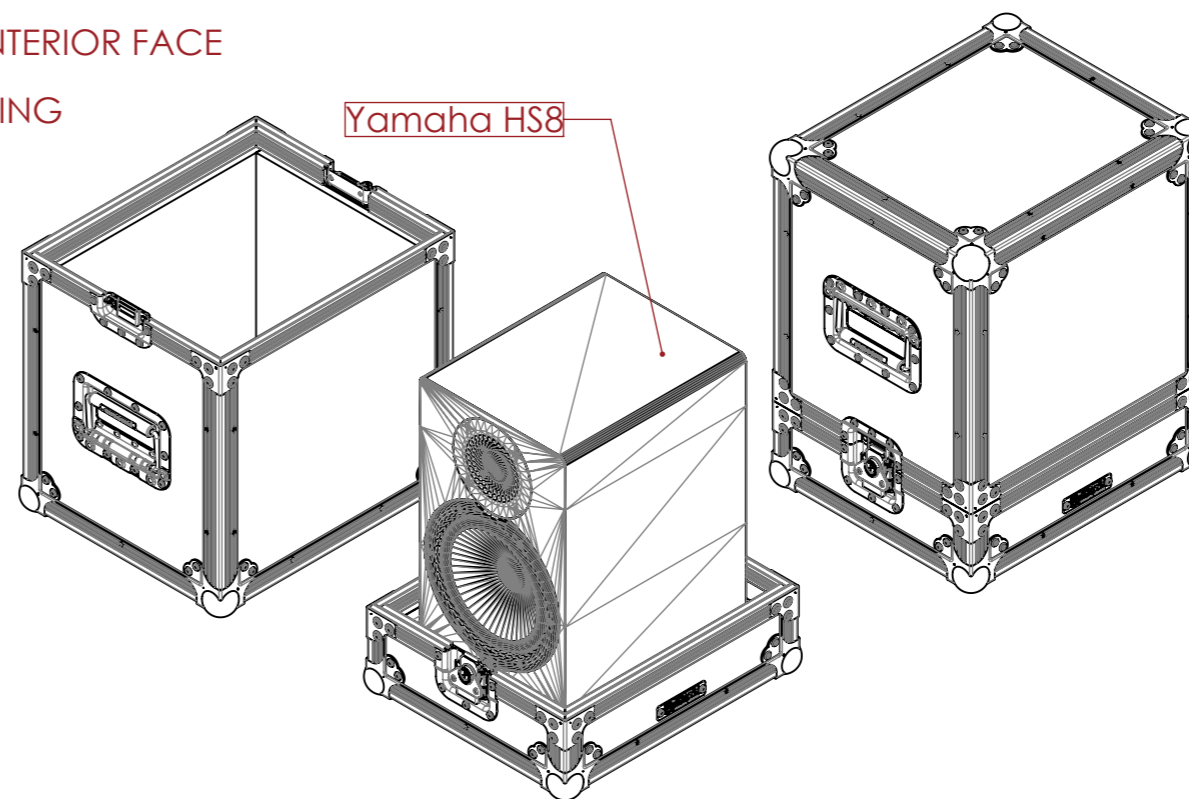

ESTIMATED WEIGHT (CASE ONLY):

11.5 KG

ITEM CODE:

SPK-YMH-HS8

DRAWN BY:

HA

CHECKED BY:

AS

SCALE:

NTS



MAIL : [sales@armorcases.com.au](mailto:sales@armorcases.com.au)  
WEB : [www.armorcases.com.au](http://www.armorcases.com.au)