

NOTES:  
UNLESS SPECIFIED IN THE DRAWING,  
ALL PRODUCTS DISPLAYED IN THIS  
DRAWING OTHER THAN THE CASE  
ITSELF IS NOT PART OF OUR PRODUCT  
OFFERING.

**PRODUCT FEATURES**

**CONSTRUCTION**

- 12MM BIRCH VENEER PLYWOOD WITH HPL EXTERIOR FACE AND PVC INTERIOR FACE
- LARGE LATCHES
- 12X ERGONOMICALLY PLACED HANDLES FOR LIFTING AND TRANSPORTING
- 4X 100MM CASTORS 2X BRAKED

**FEATURES**

- DEDICATED SPACE FOR STORING 2X M-BAR/M-BUMP ASSEMBLIES
- 2X COMPARTMENT SPACE FOR STORING ACCESSORIES (302mm L X 217mm W X 480mm H)
- COMPACT DESIGN

M-BAR & M-BUMP are to be fastened to each other using spring pins (OEM supplied) to create an assembly

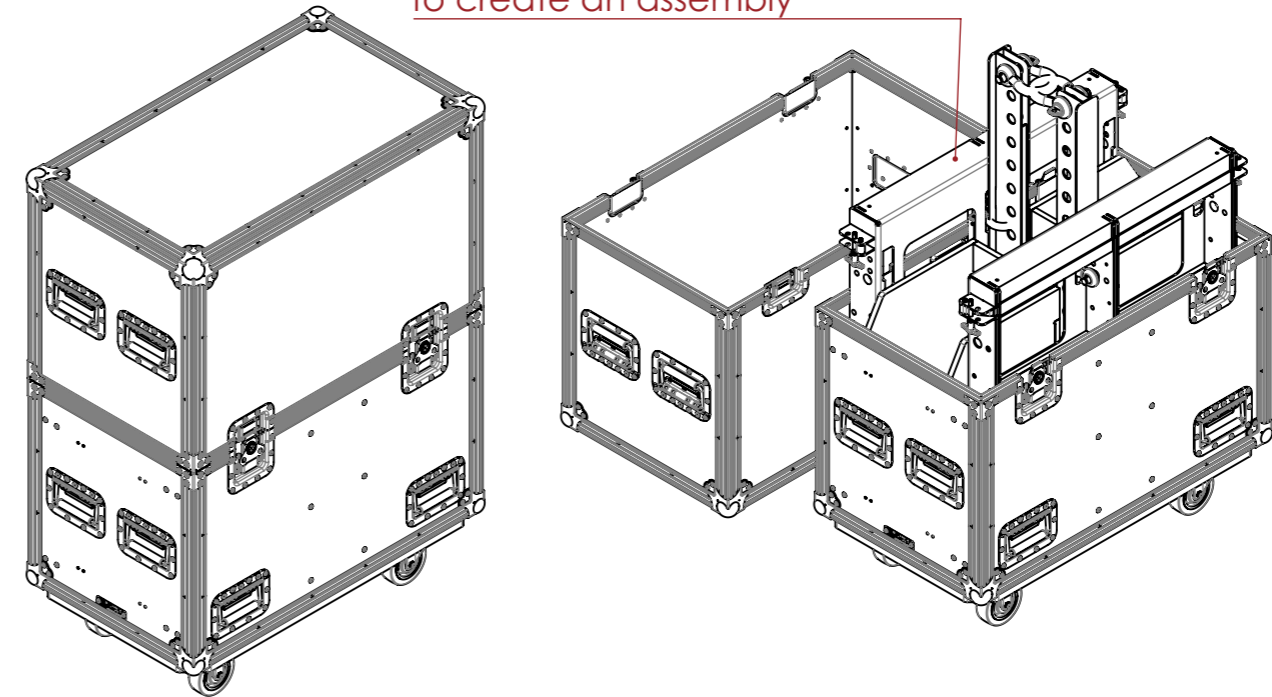

ESTIMATED WEIGHT (CASE ONLY):  
55.05 KG

ITEM CODE:  
SPK-LA-KARAI-RF

DRAWN BY: HA                      CHECKED BY: AS

SCALE:  
NTS



MAIL : sales@armorcases.com.au  
WEB : www.armorcases.com.au