

PRODUCT FEATURES

CONSTRUCTION

- 9MM BIRCH VENEER PLYWOOD WITH HPL EXTERIOR FACE AND PVC INTERIOR FACE
- ARMOR HARDWARE

FEATURES

- STORAGE FOR RIGTEC X30 PROJECTOR FRAME
- STORAGE FOR RIGTEC X30 STANDARD ATOM GRIP
- STORAGE FOR 2X LENS
- LABEL DISH FOR EASE OF RECOGNITION
- CASTOR DISH FOR EASE OF STACKING
- TRUCK FRIENDLY DIMENSIONS

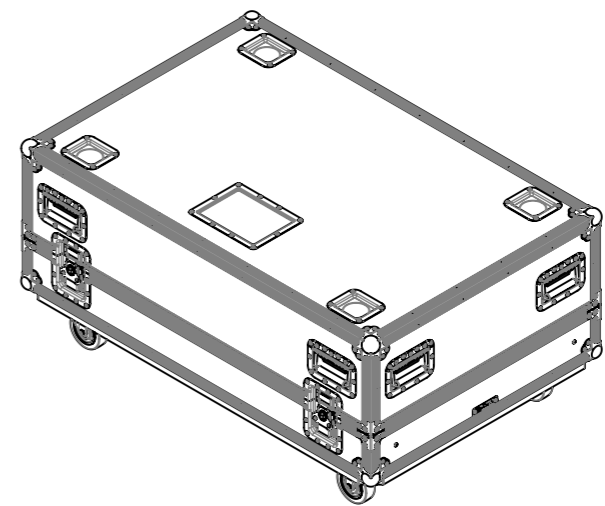
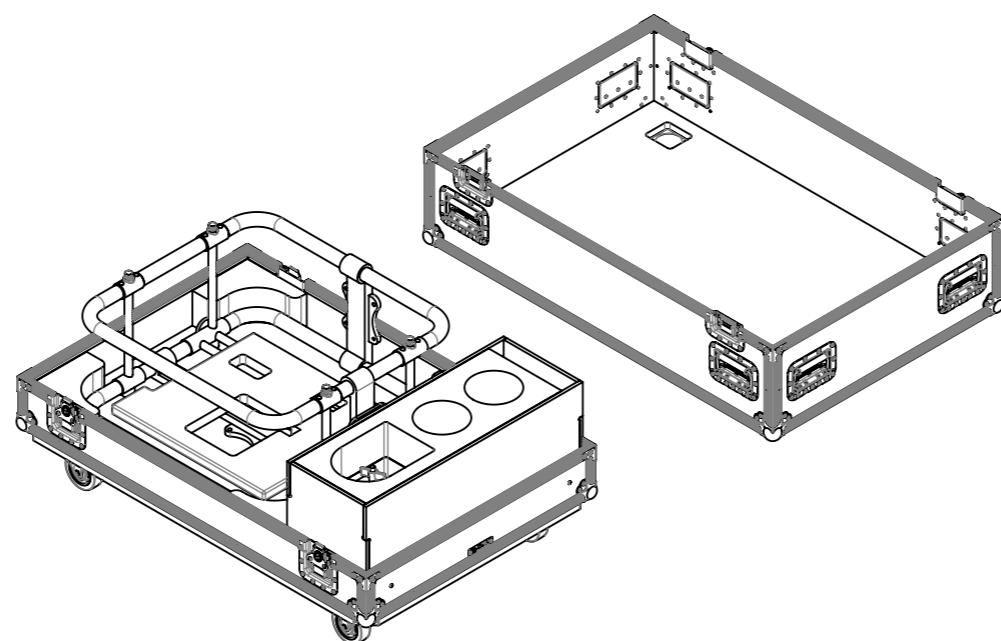
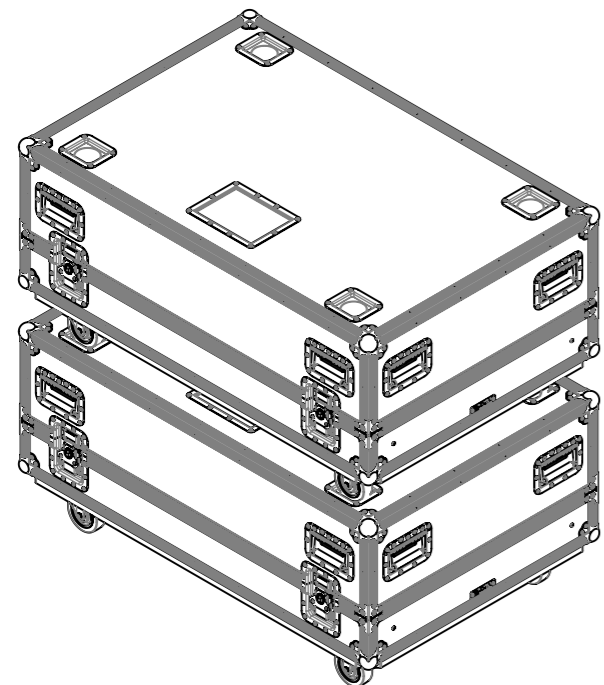
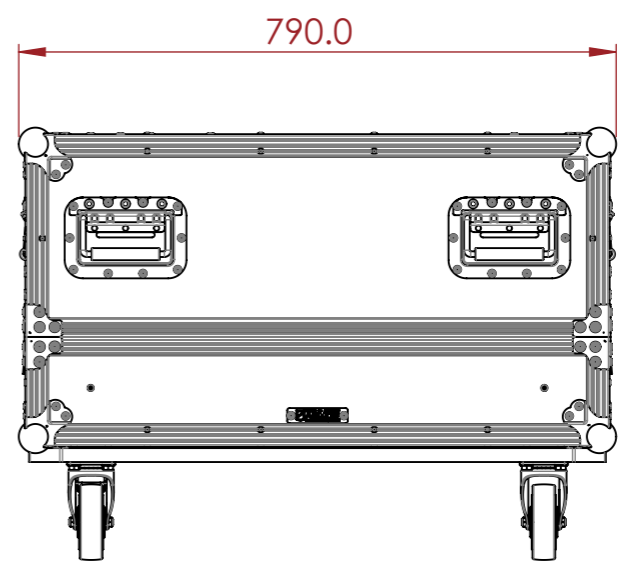
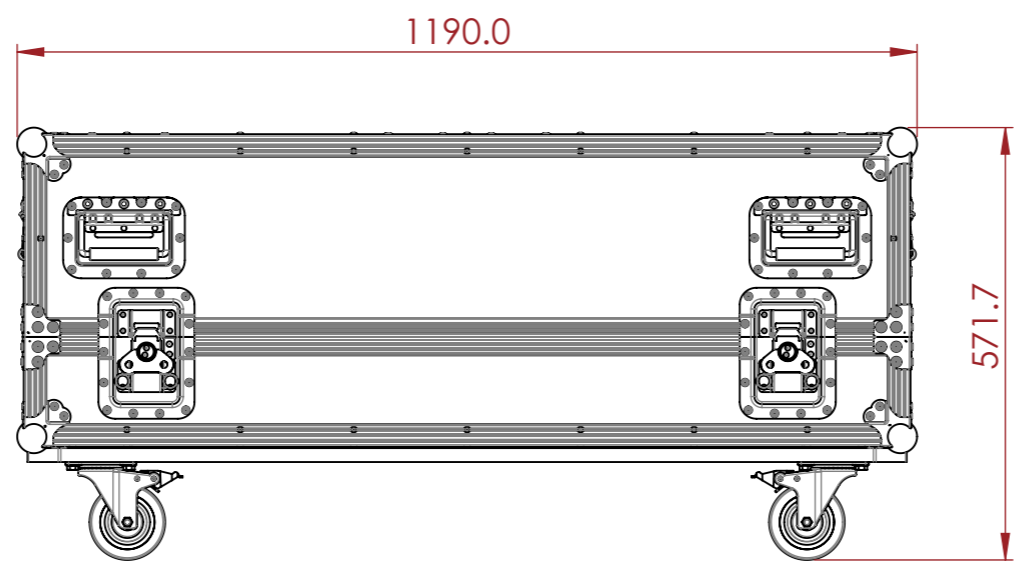

NOTES:
UNLESS SPECIFIED IN THE DRAWING,
ALL PRODUCTS DISPLAYED IN THIS
DRAWING OTHER THAN THE CASE
ITSELF IS NOT PART OF OUR PRODUCT
OFFERING.

ESTIMATED WEIGHT (CASE ONLY):
55.95 KG

ITEM CODE:
PJTR-RIGTEC-X30

DRAWN BY: K.I. CHECKED BY: AS

SCALE:
NTS



MAIL : sales@armorcases.com.au
WEB : www.armorcases.com.au