

PRODUCT FEATURES

CONSTRUCTION

- 12MM BIRCH VENEER PLYWOOD WITH HPL EXTERIOR FACE AND PVC INTERIOR FACE
- PENN ELCOM HARDWARE

FEATURES

- MOVING HEAD LIGHT CASE FOR 2X MARTIN ERA-300 LIGHTS
- 150MM WIDE STORAGE SPACE FOR ACCESSORIES
- TRUCK FRIENDLY DIMENSIONS
- LABEL DISH FOR EASE OF RECOGNITION
- CASTOR DISHES FOR EASE OF STACKING

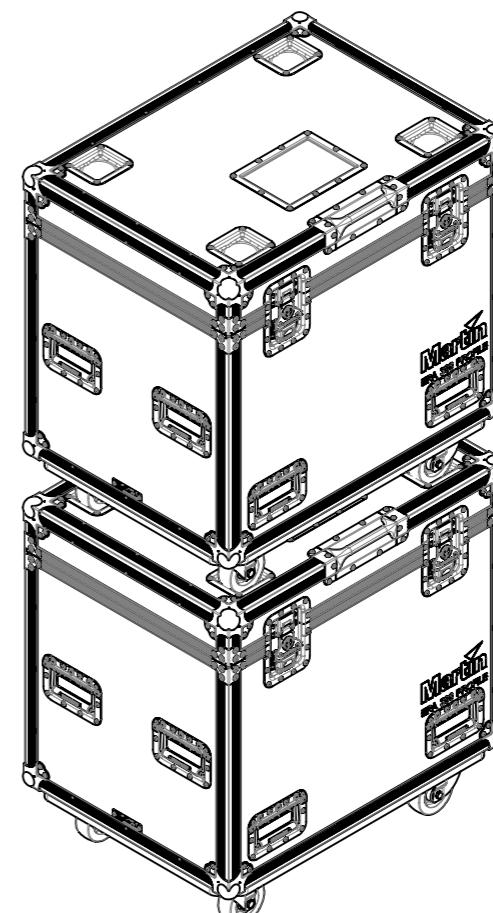
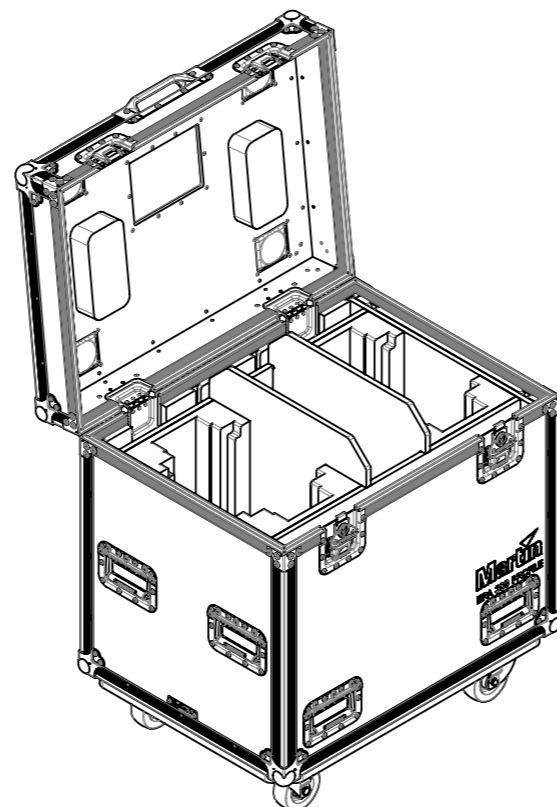
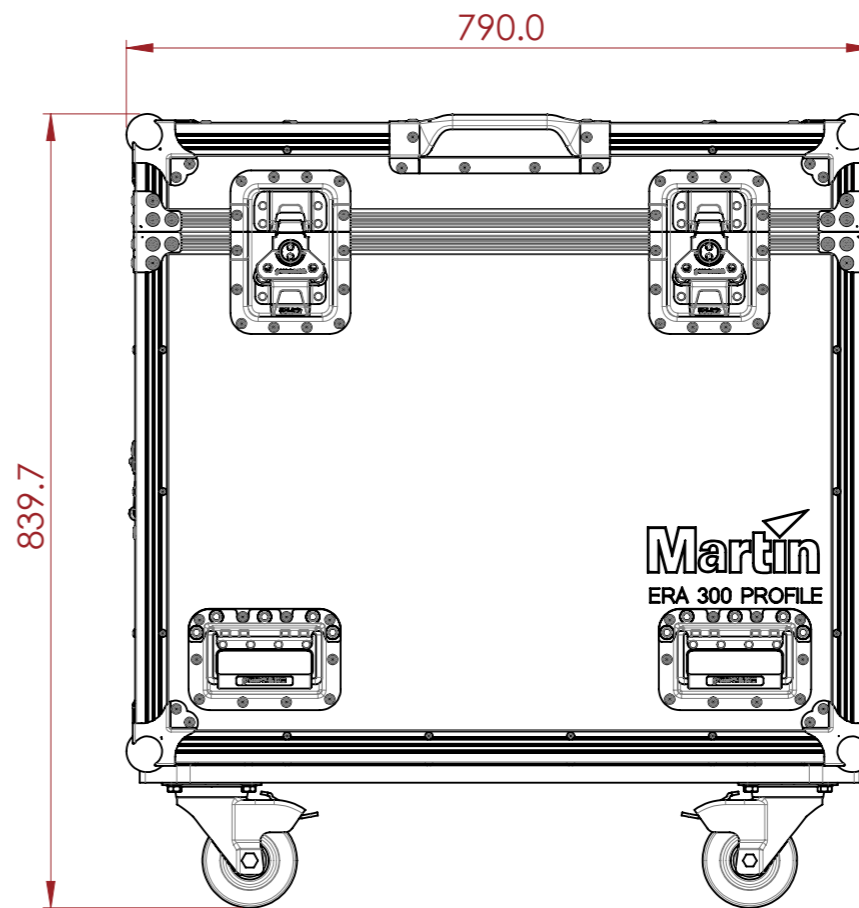
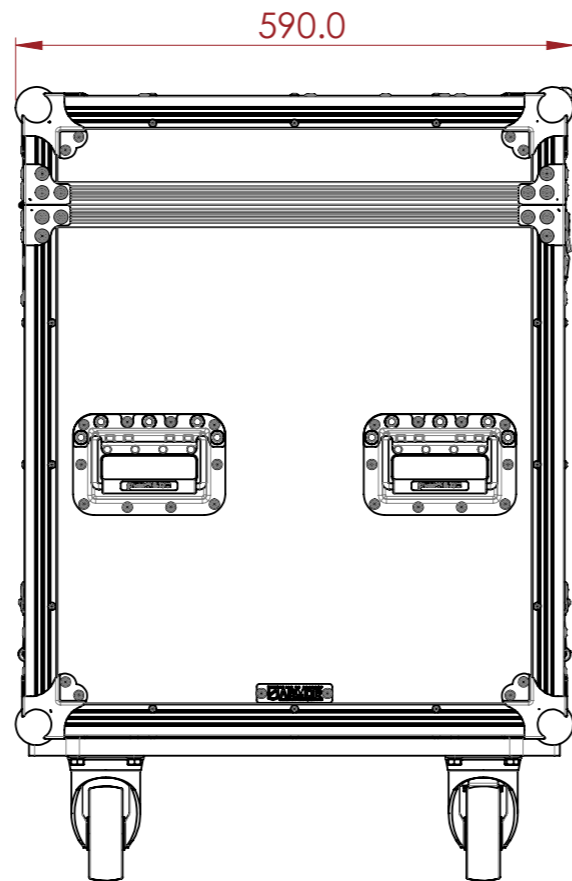

NOTES:
UNLESS SPECIFIED IN THE DRAWING,
ALL PRODUCTS DISPLAYED IN THIS
DRAWING OTHER THAN THE CASE
ITSELF IS NOT PART OF OUR PRODUCT
OFFERING.

ESTIMATED WEIGHT (CASE ONLY):

61.37 KG

ITEM CODE:

LXMH-MTN-ERA300P

DRAWN BY:

K.I

CHECKED BY:

AS

SCALE:

NTS



MAIL : sales@armorcases.com.au
WEB : www.armorcases.com.au