

NOTES:
UNLESS SPECIFIED IN THE DRAWING,
ALL PRODUCTS DISPLAYED IN THIS
DRAWING OTHER THAN THE CASE
ITSELF IS NOT PART OF OUR PRODUCT
OFFERING.

PRODUCT FEATURES

CONSTRUCTION

- 7MM HIGH QUALITY PLASTIC PANEL
- ARMOR HARDWARE WITH PENN ELCOM CORNER CASTORS AND FEET.
- 5X ERGONOMIALLY PLACED HANDLES FOR LIFTING AND TRANSPORTING
- MEDIUM LATCHES
- 3X LARGE RECESSED HANDLES
- 1X RECESSED HANDLE
- 1X EDGE HANDLE ON THE LID
- EVA38B FOAM PROTECTION

FEATURES

- DEDICATED SPACE FOR ROLAND FR-4X ACCORDION
- CORNER CASTORS AND RECESSED HANDLE
- COMPACT DESIGN

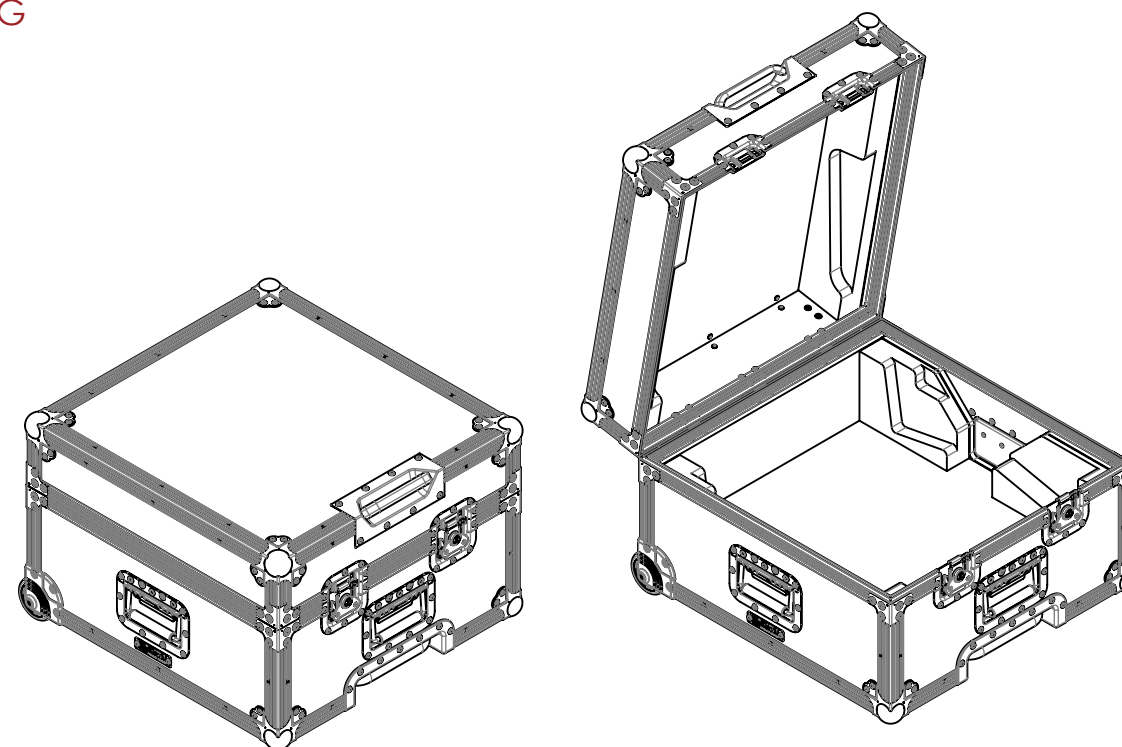

ESTIMATED WEIGHT (CASE ONLY):

13.03 KG

ITEM CODE:

ACOR-RLD-FR4X

DRAWN BY:

HA

CHECKED BY:

AS

SCALE:

NTS



MAIL : sales@armorcases.com.au
WEB : www.armorcases.com.au