

NOTES:
UNLESS SPECIFIED IN THE DRAWING,
ALL PRODUCTS DISPLAYED IN THIS
DRAWING OTHER THAN THE CASE
ITSELF IS NOT PART OF OUR PRODUCT
OFFERING.

PRODUCT FEATURES

CONSTRUCTION

- 9MM LAMINATED PLYWOOD PANEL
- ARMOR HARDWARE
- 2 x EDGE HANDLE ON TOP LID
- 1 X EDGE HANDLE ON FRONT LID
- EVA38 FOAM PROTECTION

FEATURES

- DEDICATED SPACE FOR ONYX NX2 CONTROL SYSTEM
- FRONT AND TOP LID CAN BE OPENED
- EASY TO USE LIFT OFF LID DESIGN
- CONER CASTORS

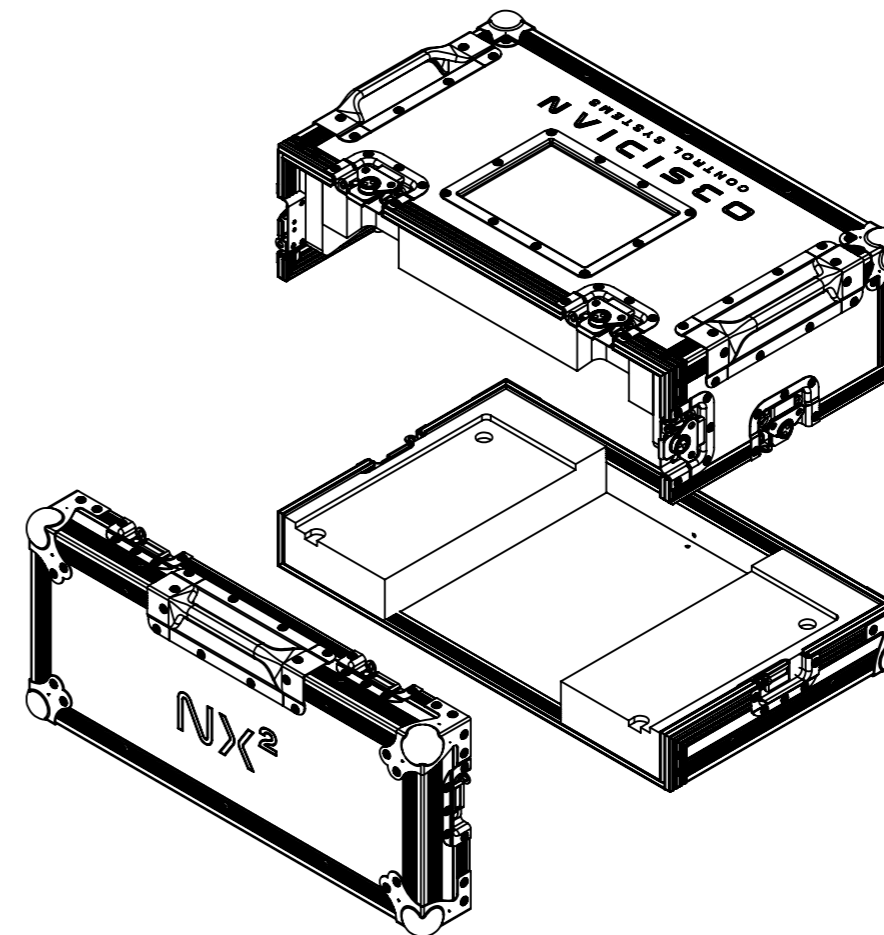
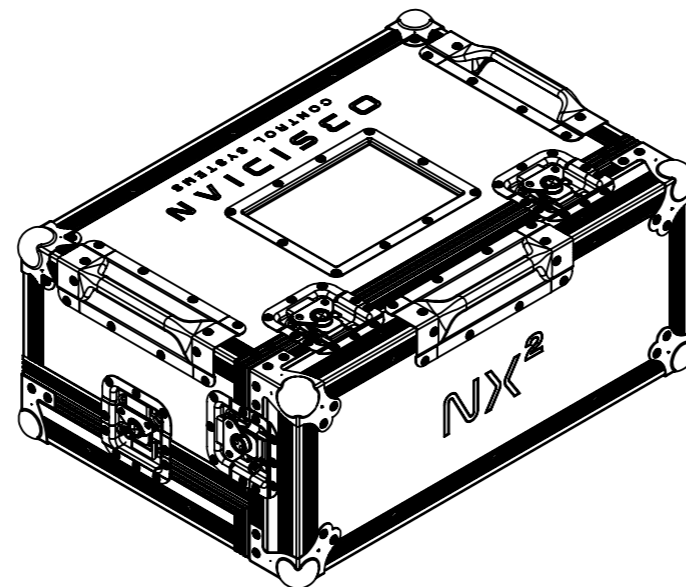

ESTIMATED WEIGHT (CASE ONLY):

11.44 KG

ITEM CODE:

LXCTRL-OBS-NX2-01

DRAWN BY:

TJ

CHECKED BY:

AS

SCALE:

NTS



MAIL : sales@armorcases.com.au
WEB : www.armorcases.com.au