

SECTION B-B
SCALE 1 : 7

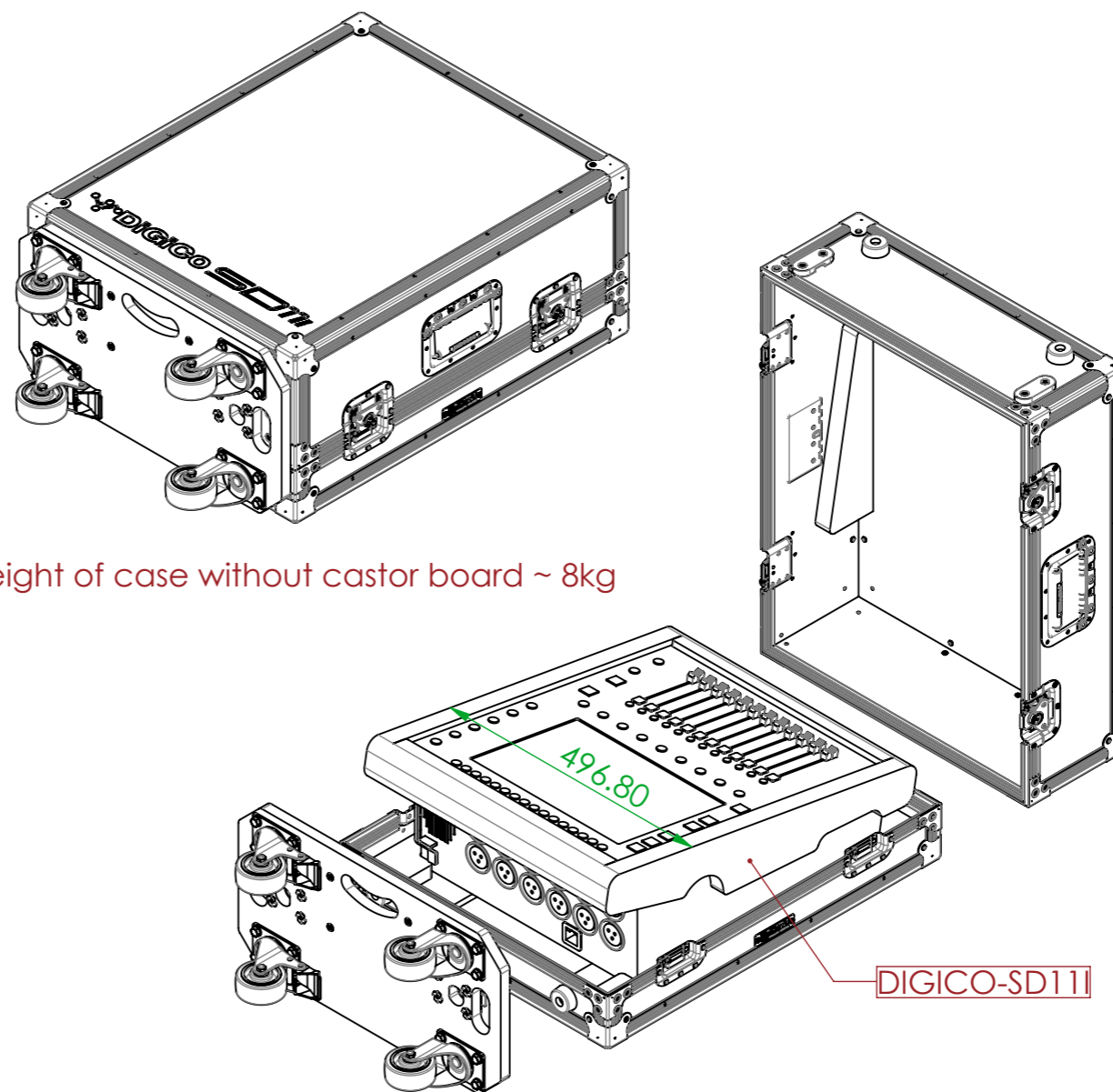

Weight of case without castor board ~ 8kg

NOTES:

REV	DESCRIPTION	DATE
0	ORIGINAL ISSUE	10/31/2022

ESTIMATED WEIGHT (CASE ONLY):

13.26 KG

QUANTITY:

1

ITEM CODE:

MIXR-DIGI-SD111-F

DRAWN BY:

HA

CHECKED BY:

AS

SCALE:

NTS



MAIL : sales@armorcases.com.au
 WEB : www.armorcases.com.au