

SECTION A-A

LIGHT FOAM SHELL IS NOT INCLUDED WITH THIS PRODUCT

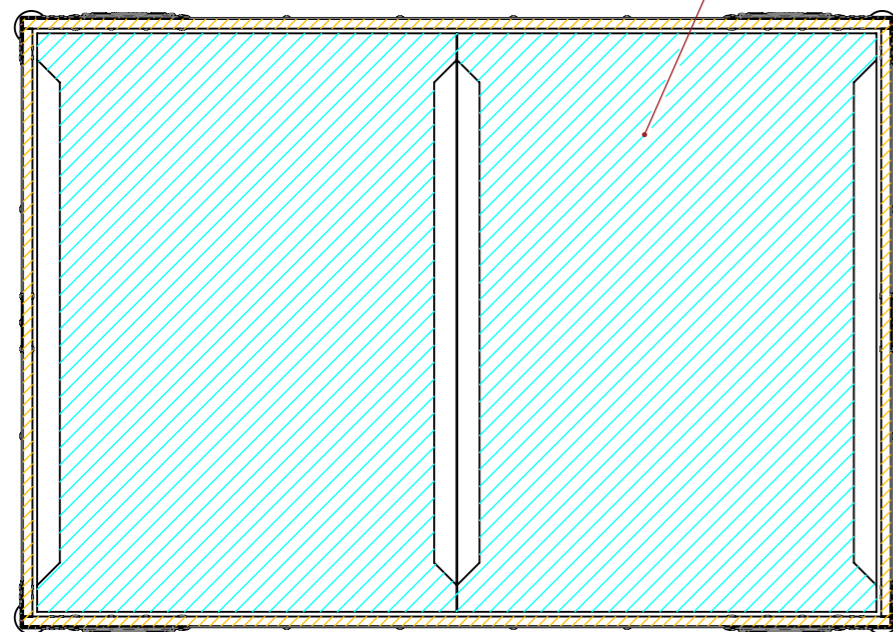

SECTION B-B

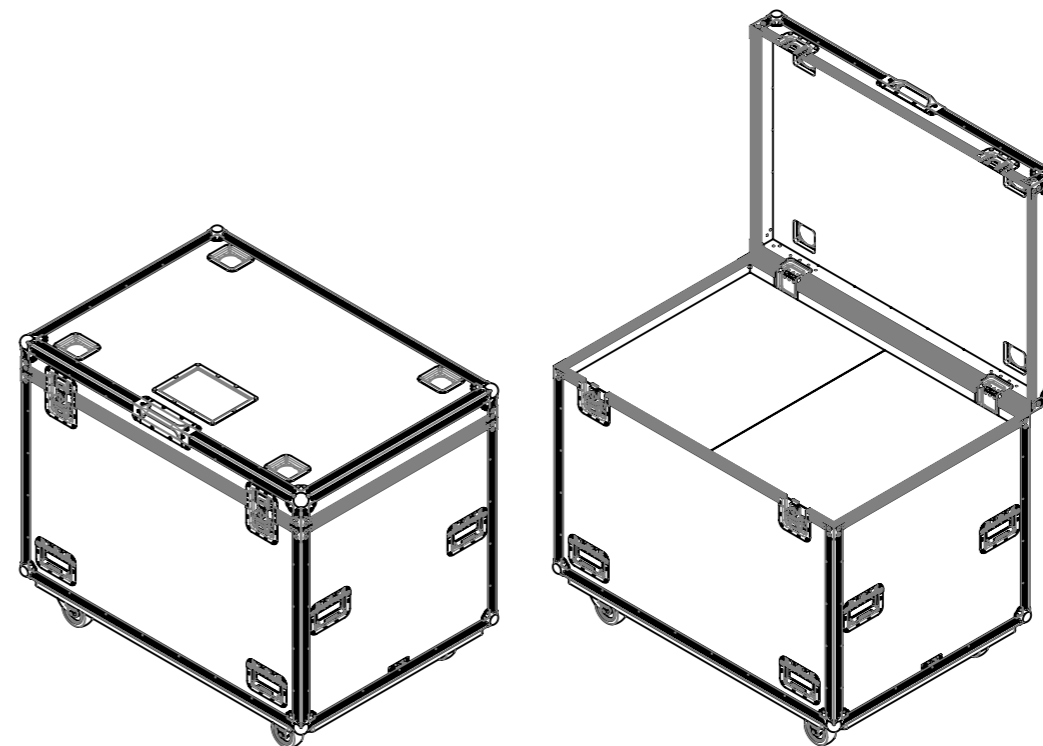

NOTES:

REV	DESCRIPTION	DATE
0	ORIGINAL ISSUE	10/31/2022

ESTIMATED WEIGHT (CASE ONLY):

**69.13 KG**

QUANTITY:

**1**

ITEM CODE:

**LXMH-AYRTON-DOMINO**

DRAWN BY:

**KI**

CHECKED BY:

**AS**

SCALE:

**NTS**



MAIL : [sales@armorcases.com.au](mailto:sales@armorcases.com.au)  
 WEB : [www.armorcases.com.au](http://www.armorcases.com.au)