

SECTION A-A

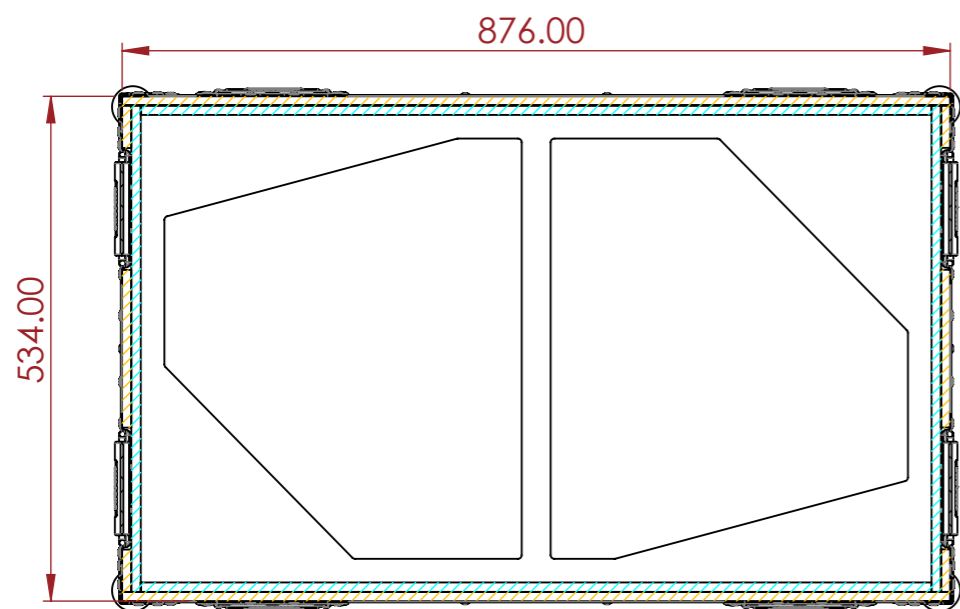

SECTION B-B

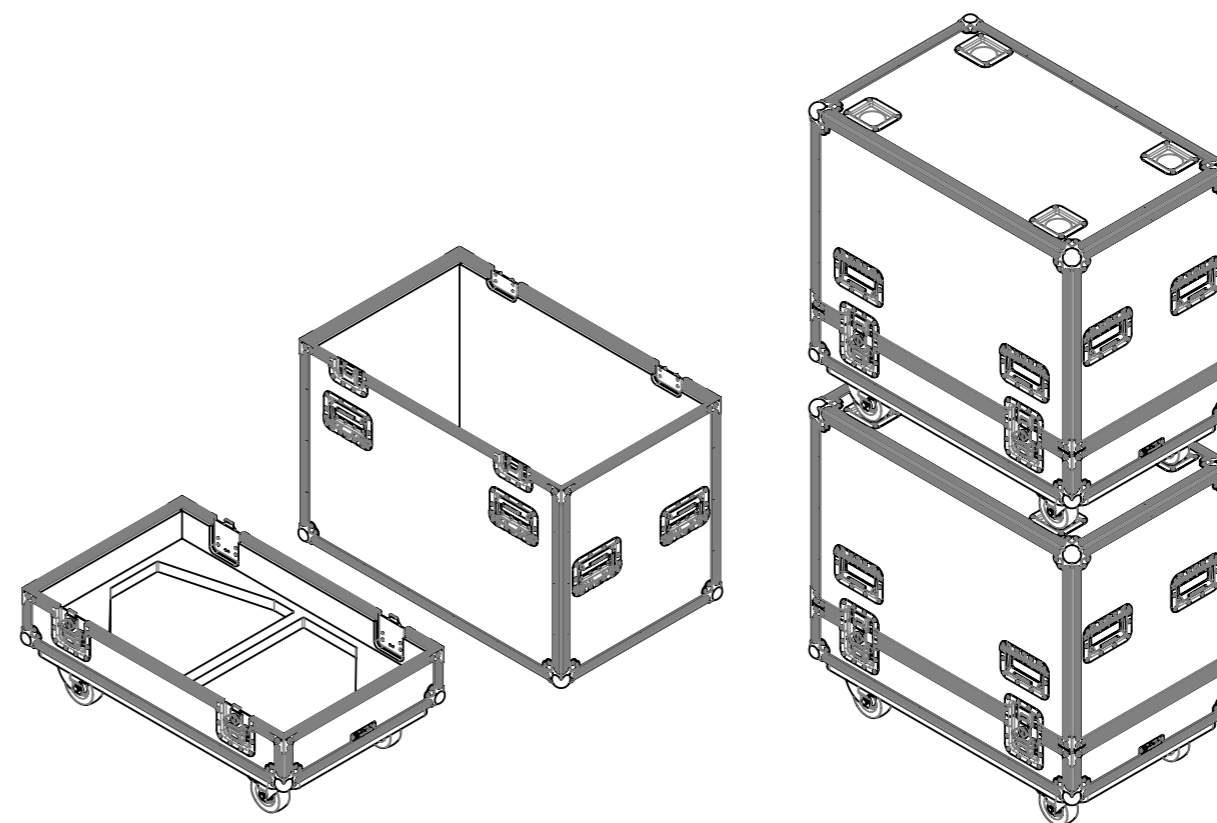

NOTES:

| REV | DESCRIPTION | DATE |
|-----|----------------|------------|
| 0 | ORIGINAL ISSUE | 10/31/2022 |
| | | |
| | | |
| | | |
| | | |
| | | |
| | | |
| | | |

ESTIMATED WEIGHT (CASE ONLY):

40.24 KG

QUANTITY:

1

ITEM CODE:

SPK-NEXO-PS15-R2

DRAWN BY:

KI

CHECKED BY:

AS

SCALE:

NTS



MAIL : sales@armorcases.com.au
 WEB : www.armorcases.com.au

1 2 3 4 5 6 7 8 9 10 11 12 13 14 15 16

A B C D E F G H

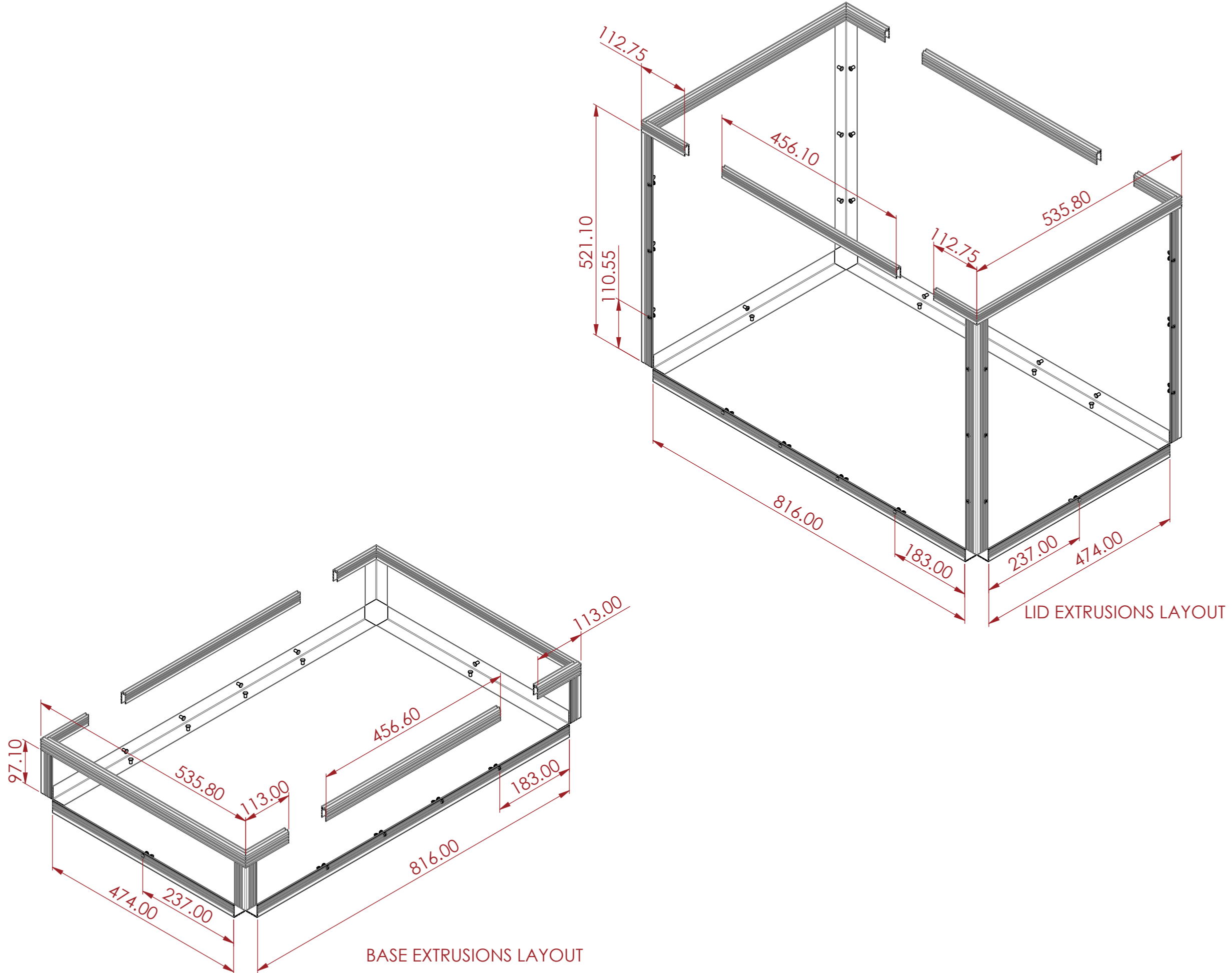

NOTES:

| REV | DESCRIPTION | DATE |
|-----|----------------|------------|
| 0 | ORIGINAL ISSUE | 10/31/2022 |
| | | |
| | | |
| | | |
| | | |
| | | |
| | | |
| | | |
| | | |

ESTIMATED WEIGHT (CASE ONLY):
40.24 KG

QUANTITY:
1

ITEM CODE:
SPK-NEXO-PS15-R2

DRAWN BY: **KI** CHECKED BY: **AS**

SCALE:
NTS



MAIL : sales@armorcases.com.au
 WEB : www.armorcases.com.au

1 2 3 4 5 6 7 8 9 10 11 12 13 14 15 16

H

| ITEM NO. | ERP FILE NAME | QTY. |
|----------|---------------------|------|
| 13 | HDL-PN-H7151Z | 8 |
| 14 | RVT-0520 | 252 |
| 15 | LAT-PN-L944/527MOL3 | 4 |
| 16 | BRC-B4501M | 8 |
| 17 | CNR-C3102M-2MM | 8 |
| 21 | DISH-6503 | 4 |
| 37 | LAT-PN-L944/527MOL3 | 4 |
| 38 | BDG-ARMOR | 2 |
| 39 | CSTR-PN-W9000-V6 | 2 |
| 40 | BLT-HEX-M8X20 | 4 |
| 41 | BLT-HEX-M8X35 | 12 |
| 42 | NUT-T-M8 | 16 |
| 43 | WSHR-M8-RING | 16 |
| 44 | CSTR-PN-W9008-V6 | 2 |

NOTES:

| REV | DESCRIPTION | DATE |
|-----|----------------|------------|
| 0 | ORIGINAL ISSUE | 10/31/2022 |
| | | |
| | | |
| | | |
| | | |
| | | |
| | | |
| | | |
| | | |

ESTIMATED WEIGHT (CASE ONLY):
40.24 KG

QUANTITY:
1

ITEM CODE:
SPK-NEXO-PS15-R2

DRAWN BY: **KI** CHECKED BY: **AS**

SCALE:
NTS



MAIL : sales@armorcases.com.au
 WEB : www.armorcases.com.au