

SECTION A-A

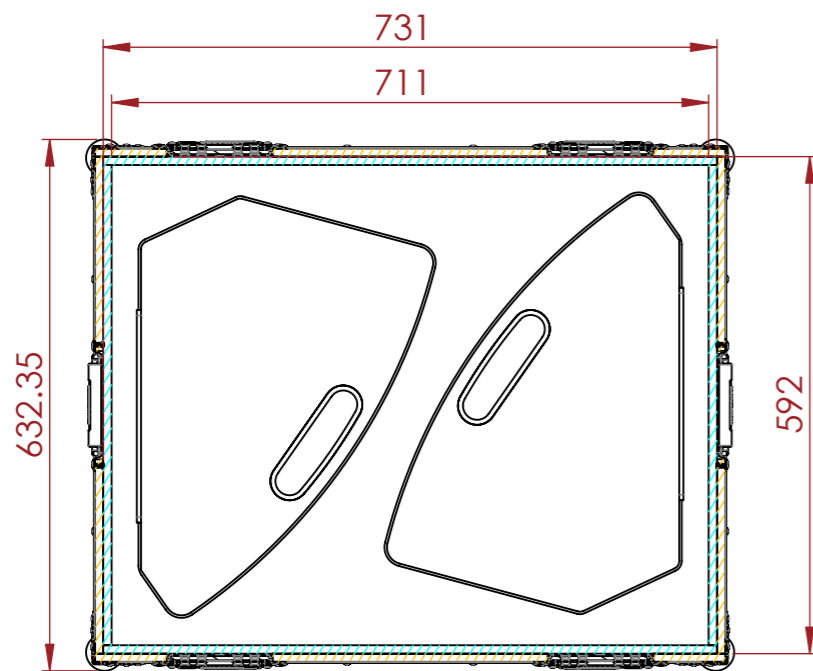

SECTION B-B

D&B AUDIOTECHNIK - MAX2 Monitor

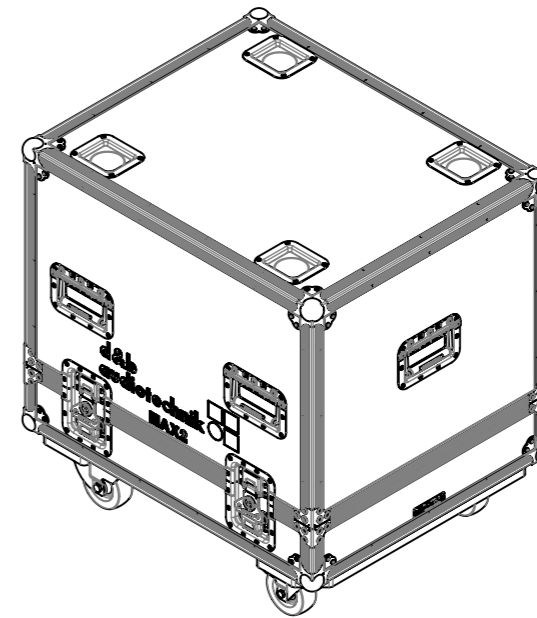
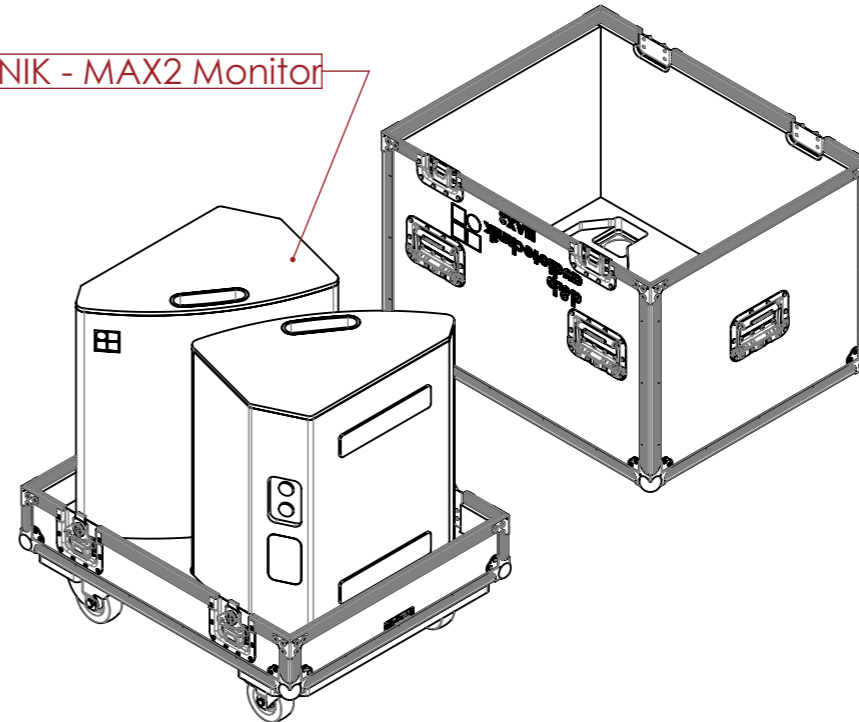

NOTES:

REV	DESCRIPTION	DATE
0	ORIGINAL ISSUE	10/31/2022

ESTIMATED WEIGHT (CASE ONLY):

**33.74 KG**

QUANTITY:

**1**

ITEM CODE:

**SPK-DB-MAX2**

DRAWN BY:

**HA**

CHECKED BY:

**AS**

SCALE:

**NTS**



ADD : 45/7-9 Percy St, Auburn,  
NSW 2144, Australia  
PH : 02 9188 6801  
MAIL : sales@armorcases.com.au  
WEB : www.armorcases.com.au

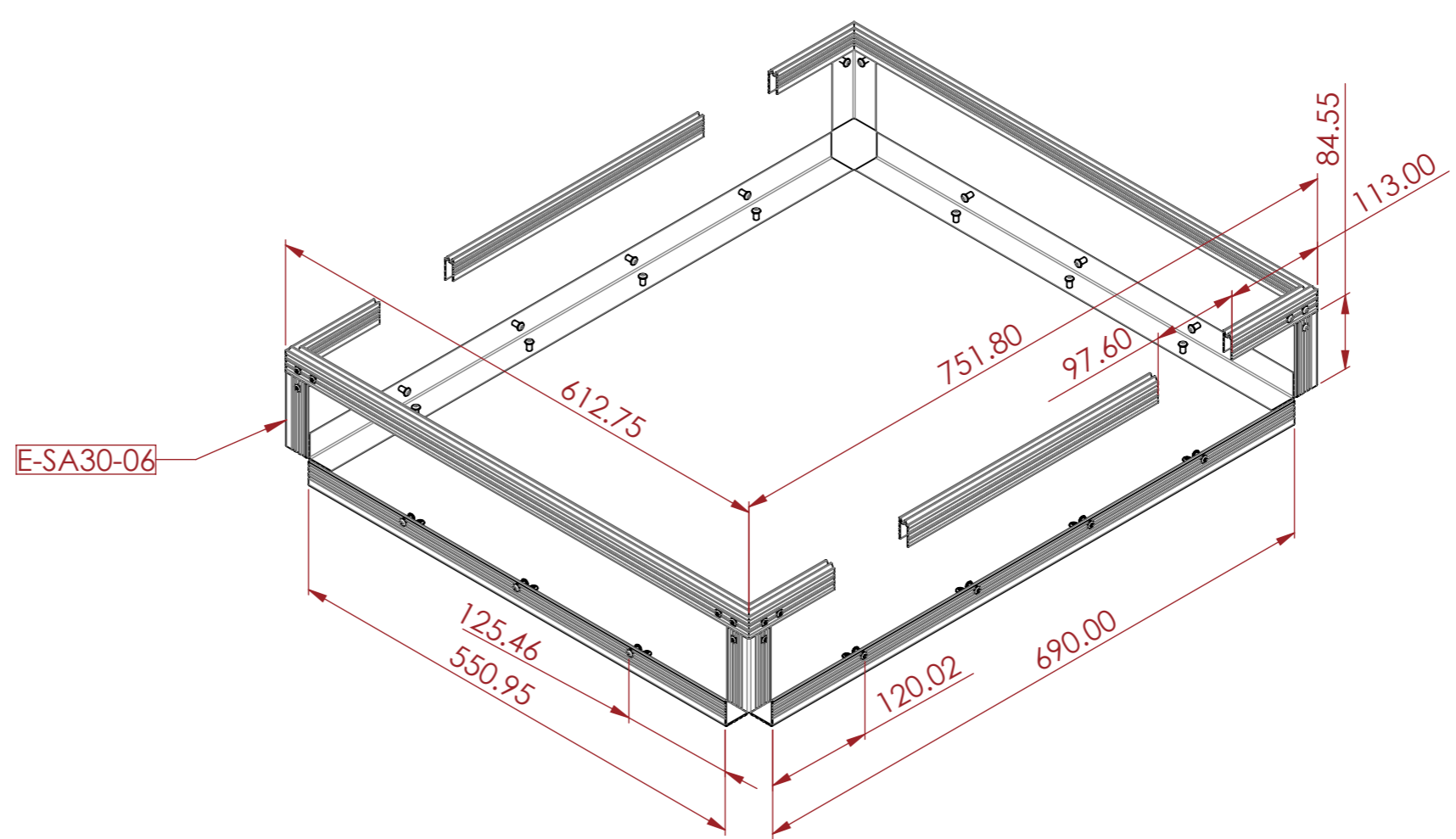
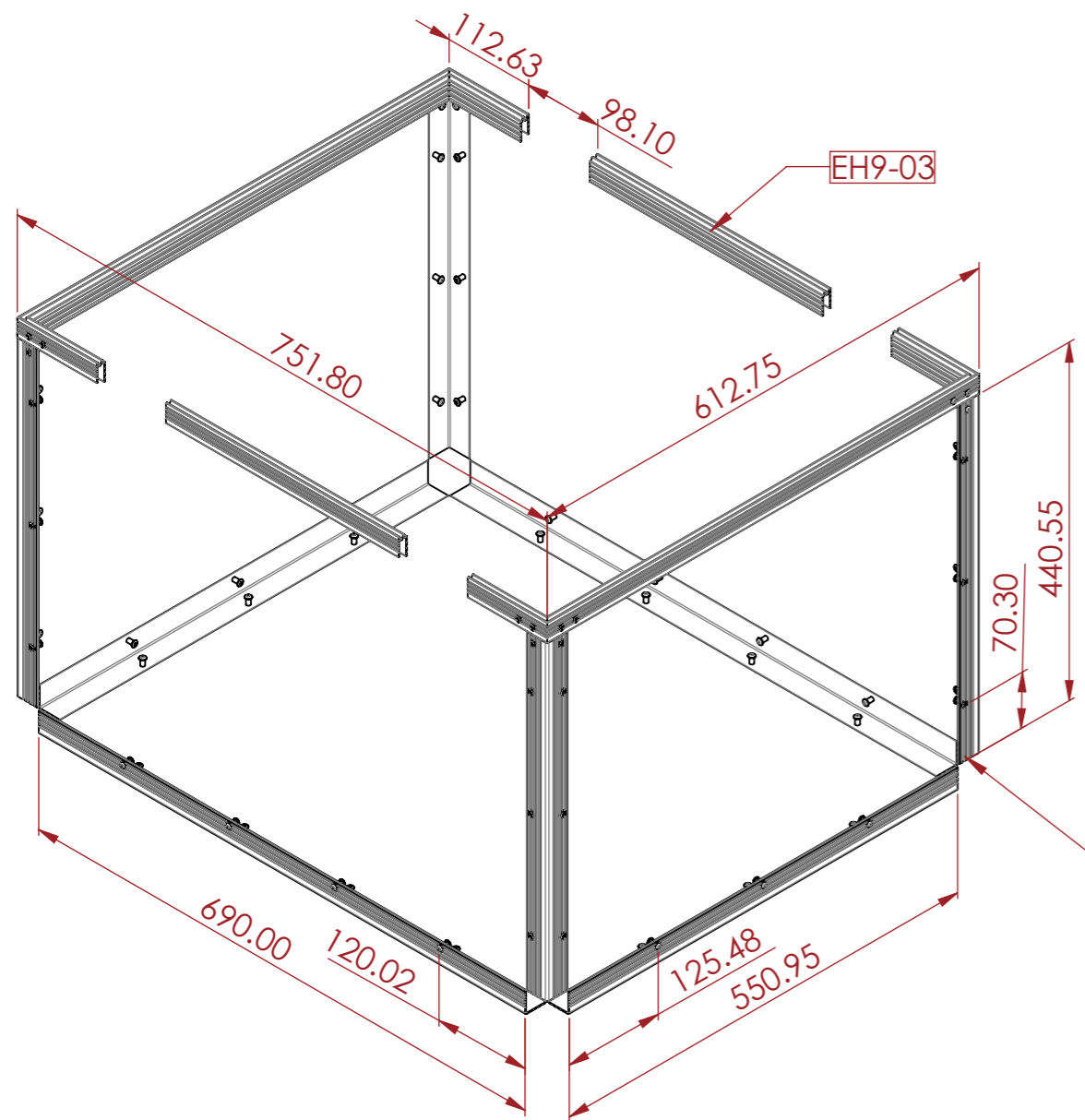

NOTES:

REV	DESCRIPTION	DATE
0	ORIGINAL ISSUE	10/31/2022

ESTIMATED WEIGHT (CASE ONLY):  
**33.74 KG**

QUANTITY:  
**1**

ITEM CODE:  
**SPK-DB-MAX2**

DRAWN BY: **HA**      CHECKED BY: **AS**

SCALE:  
**NTS**



ADD : 45/7-9 Percy St, Auburn,  
 NSW 2144, Australia  
 PH : 02 9188 6801  
 MAIL : sales@armorcases.com.au  
 WEB : www.armorcases.com.au

ITEM NO.	ERP FILE NAME	QTY.
13	HDL-PN-H7151Z	6
14	RVT-0520	232
15	LAT-PN-L944/527MOL3	4
16	BRC-B4501M	8
17	CNR-C3102M-2MM	8
22	DISH-6503	4
40	LAT-PN-L944/527MOL3	4
41	BDG-ARMOR	2
42	CSTR-PN-W9000-V6	2
43	NUT-T-M8	18
44	BLT-HEX-M8X35-SS	14
45	WSHR-M8-RING	16
46	BLT-HEX-M8X20-SS	4
47	CSTR-PN-W9008-V6	2

NOTES:

REV	DESCRIPTION	DATE
0	ORIGINAL ISSUE	10/31/2022

ESTIMATED WEIGHT (CASE ONLY):  
**33.74 KG**

QUANTITY:  
**1**

ITEM CODE:  
**SPK-DB-MAX2**

DRAWN BY: **HA**      CHECKED BY: **AS**

SCALE:  
**NTS**



ADD : 45/7-9 Percy St, Auburn,  
NSW 2144, Australia  
PH : 02 9188 6801  
MAIL : sales@armorcases.com.au  
WEB : www.armorcases.com.au