

NOTES:
 Test fit actual item before finishing case building (REMOVE THIS NOTE IF THERE WERE NO ACTUAL ITEM TO FIT IN)

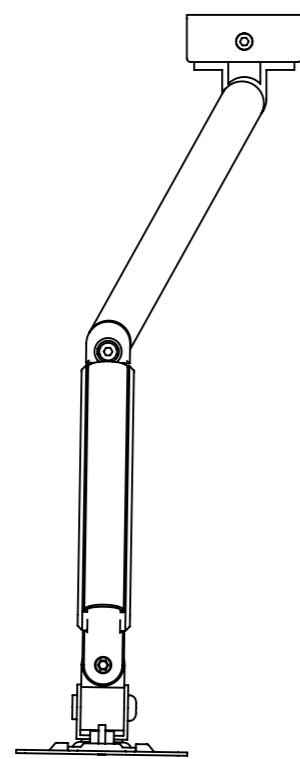

TOP VIEW

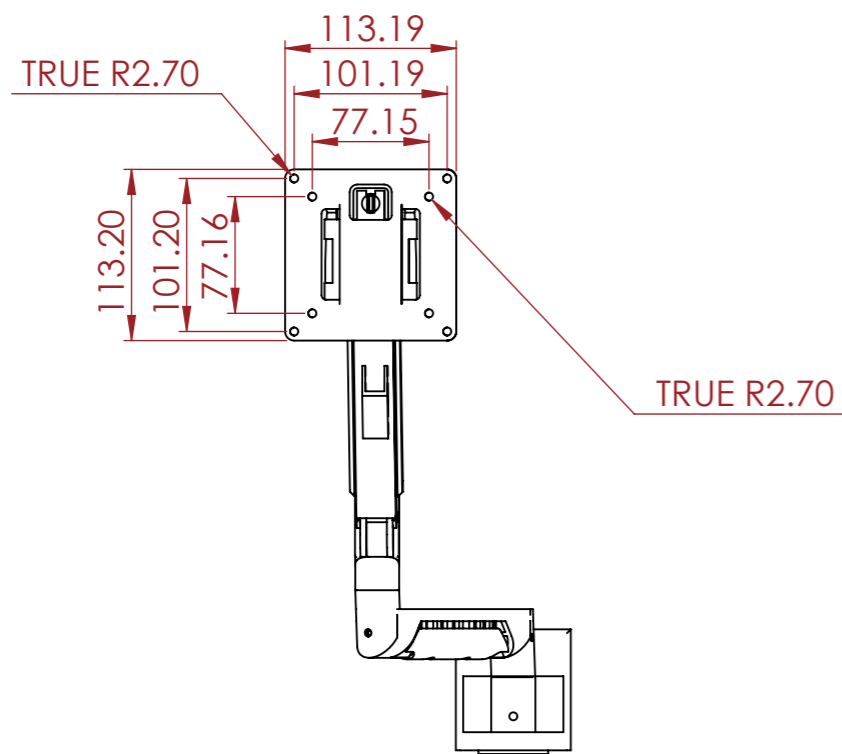
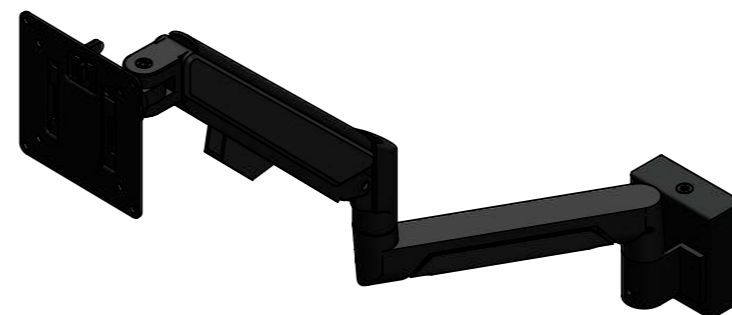

FRONT VIEW

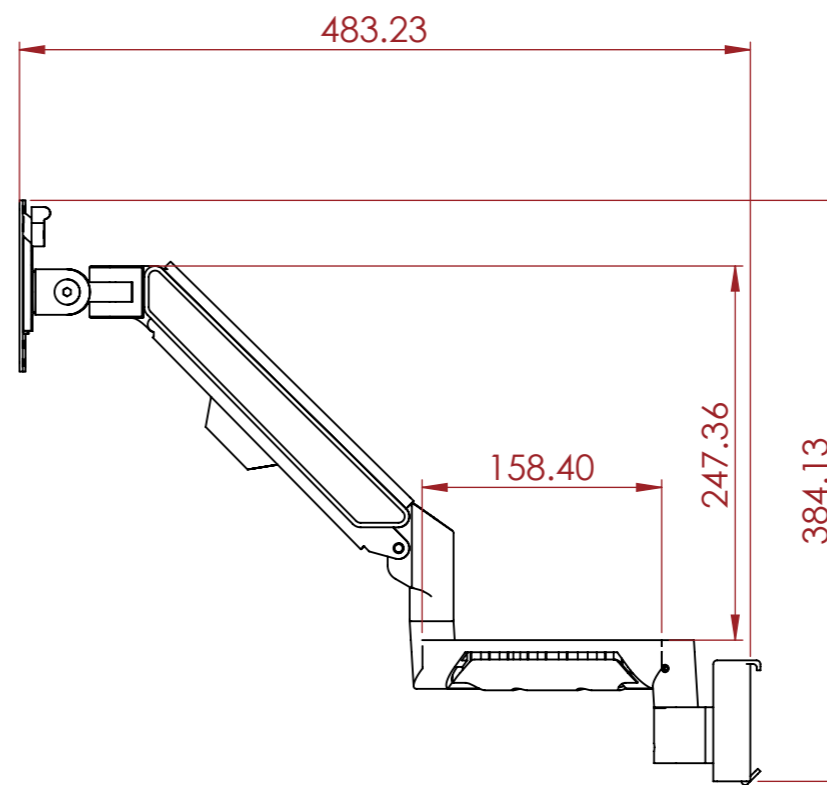

SIDE VIEW

| REV | DESCRIPTION | DATE |
|-----|----------------|------------|
| 0 | ORIGINAL ISSUE | 10/31/2022 |
| | | |
| | | |
| | | |
| | | |
| | | |
| | | |
| | | |
| | | |

ESTIMATED WEIGHT:

QUANTITY:

ITEM CODE:

ZL104 VESA ARM

DRAWN BY:

CHECKED BY:

SCALE:

NTS



ADD : 45/7-9 Percy St, Auburn,
 NSW 2144, Australia
 PH : 02 9188 6801
 MAIL : sales@armorcases.com.au
 WEB : www.armorcases.com.au