

Front Cutout View

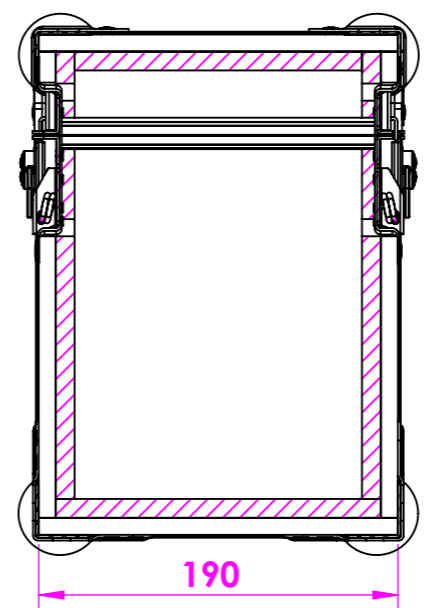

Side Cutout View

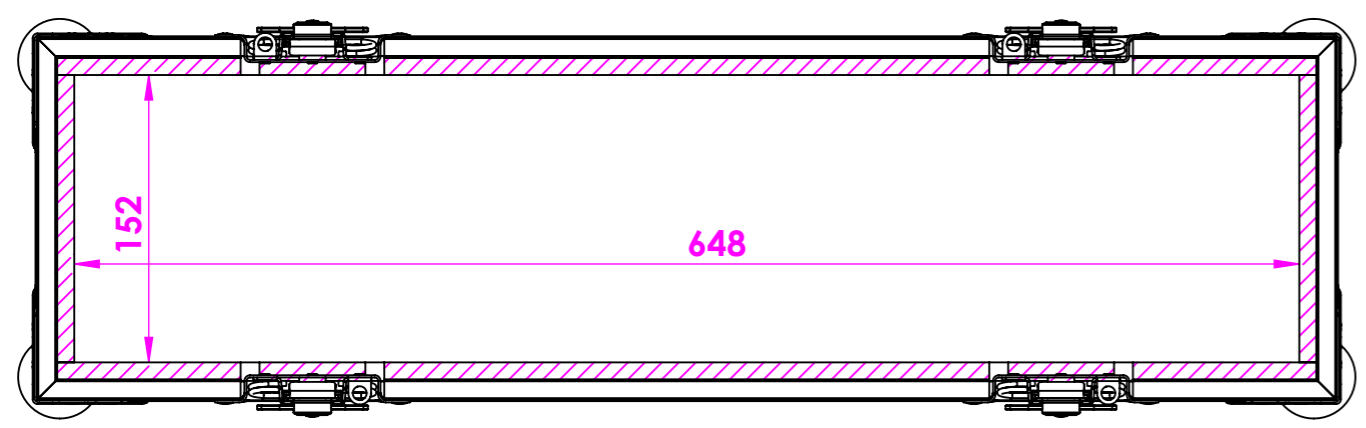

Top Cutout View

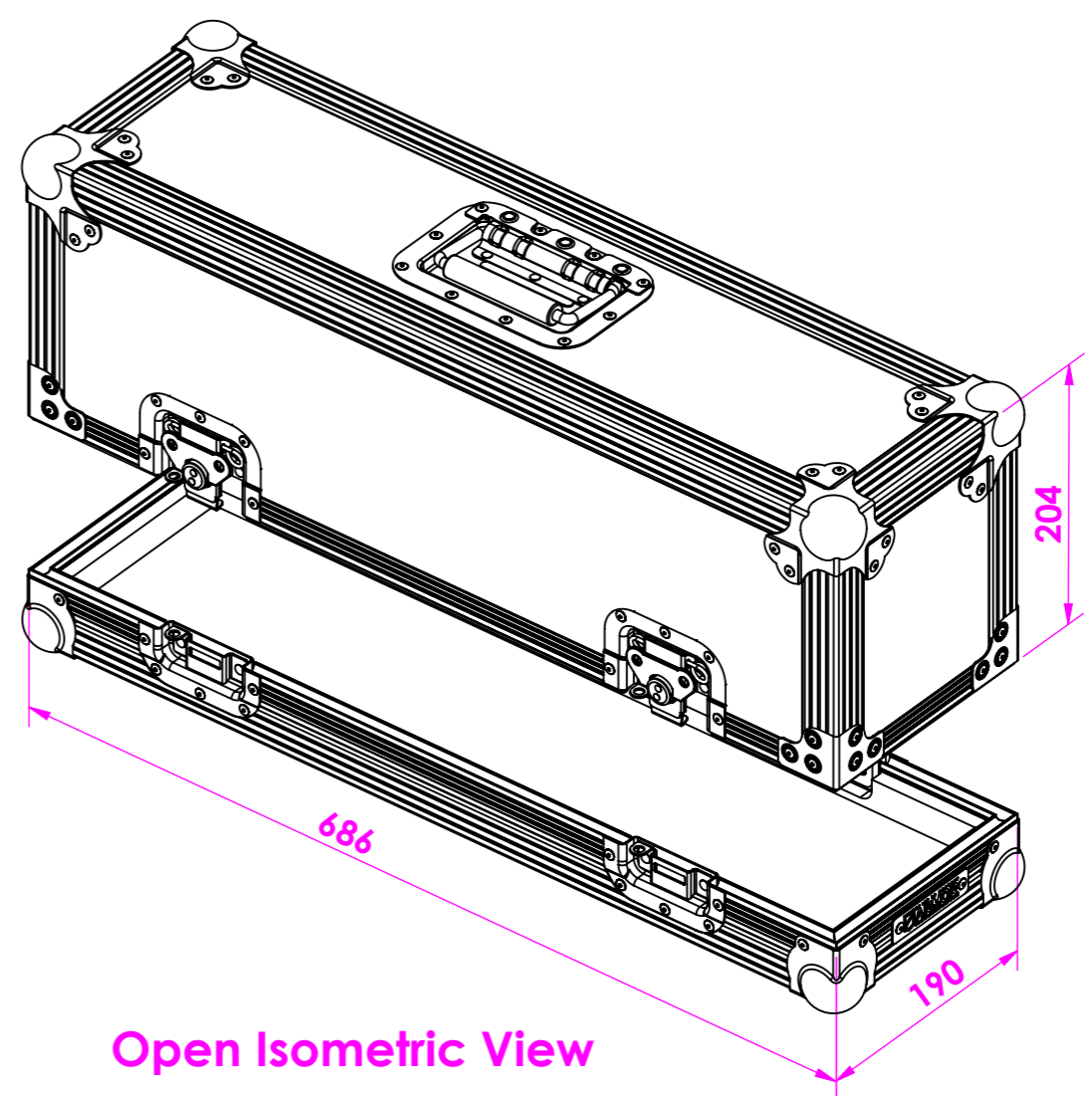

Open Isometric View

Item Number	Part Number	Description	QTY.
1	C1302	Ball Corner	4
2	C1359	Ball Brace	4
3	H1101	Handle	1
4	L2208	Latches	4
5	YR-4501	Brace	4

NOTES:
10mm EVA lining

CUSTOMER:

DUE DATE:
04/27/2021

QUANTITY:
01

PANEL FINISH:
Black Hexa Exterior

HARDWARE:
List Attached

DRAWING:
Fender Super Sonic Amp X1

DRAWN BY: EM CHECKED BY: AS

SCALE: 1:1 REVISION: 0



ADD : 45/7-9 Percy St, Auburn,
NSW 2144, Australia
PH : 02 9188 6801
MAIL : sales@armorcases.com.au
WEB : www.armorcases.com.au