

NOTES:
 P701B(Navy Blue exterior and Black interior) Panels are used .

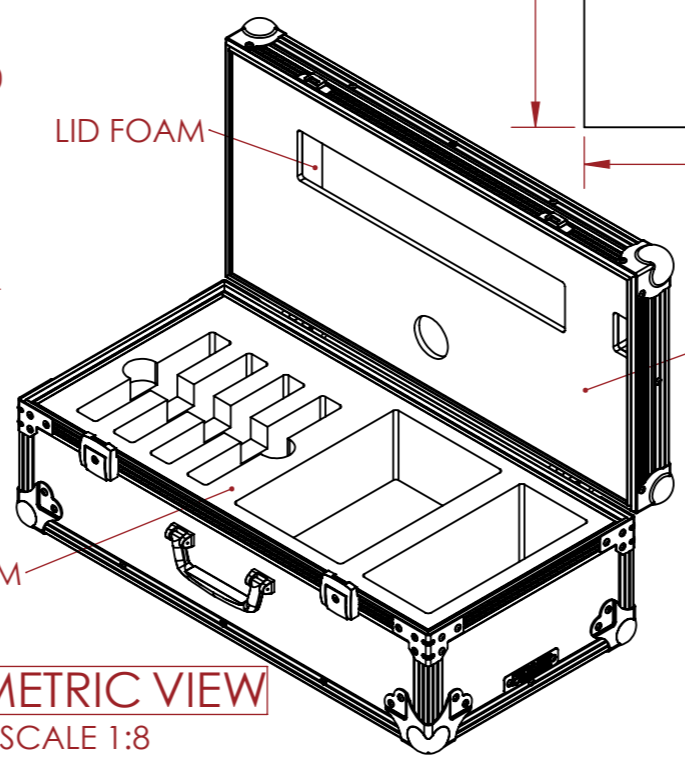
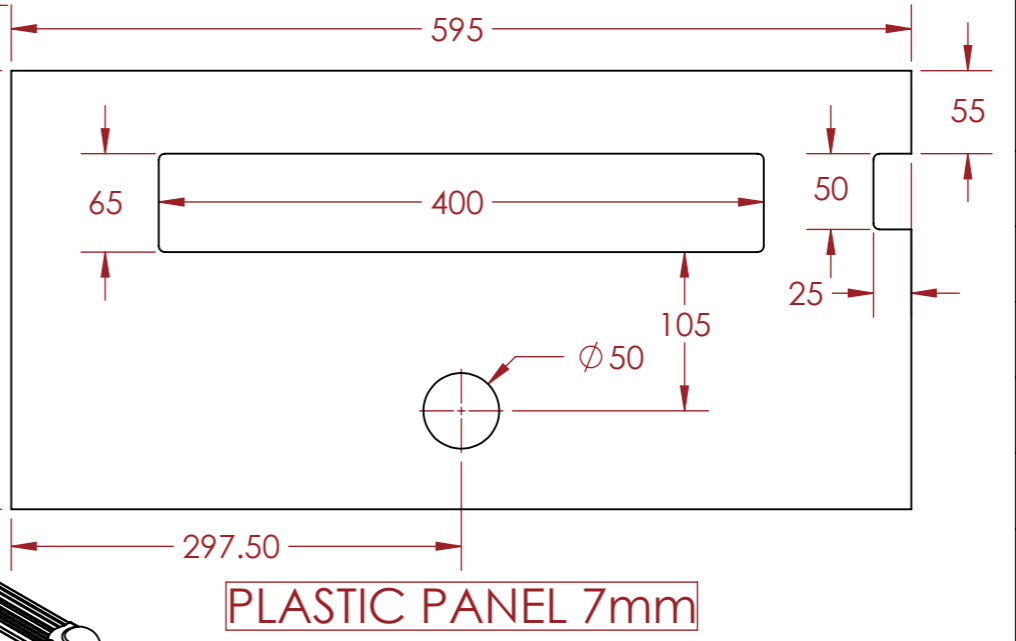
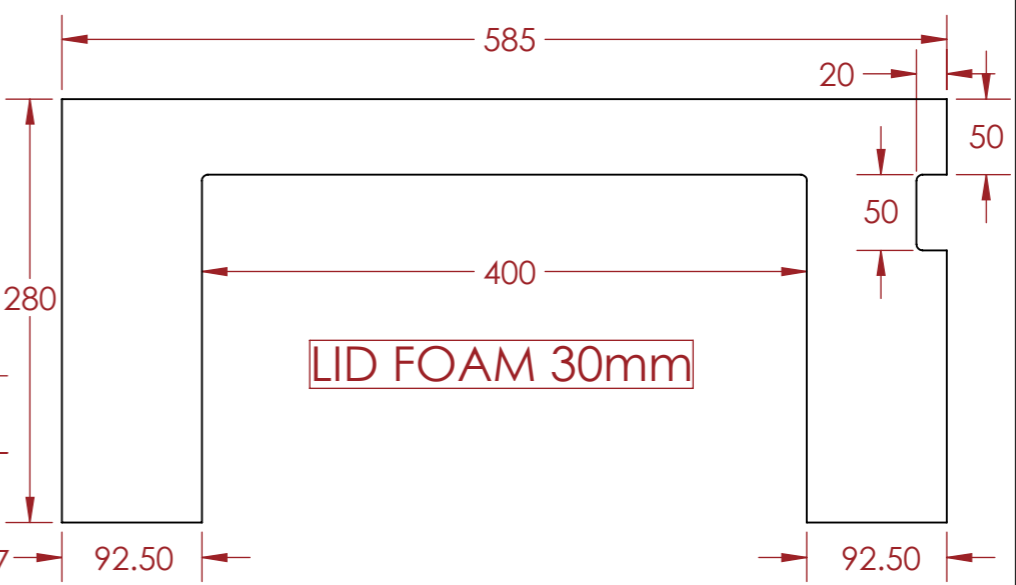
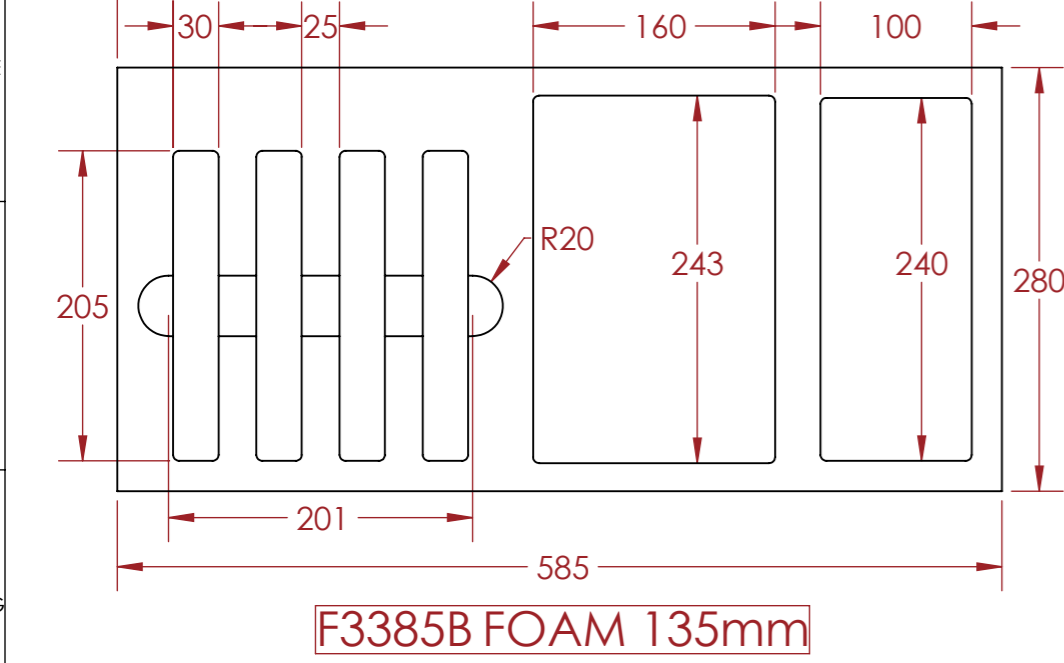
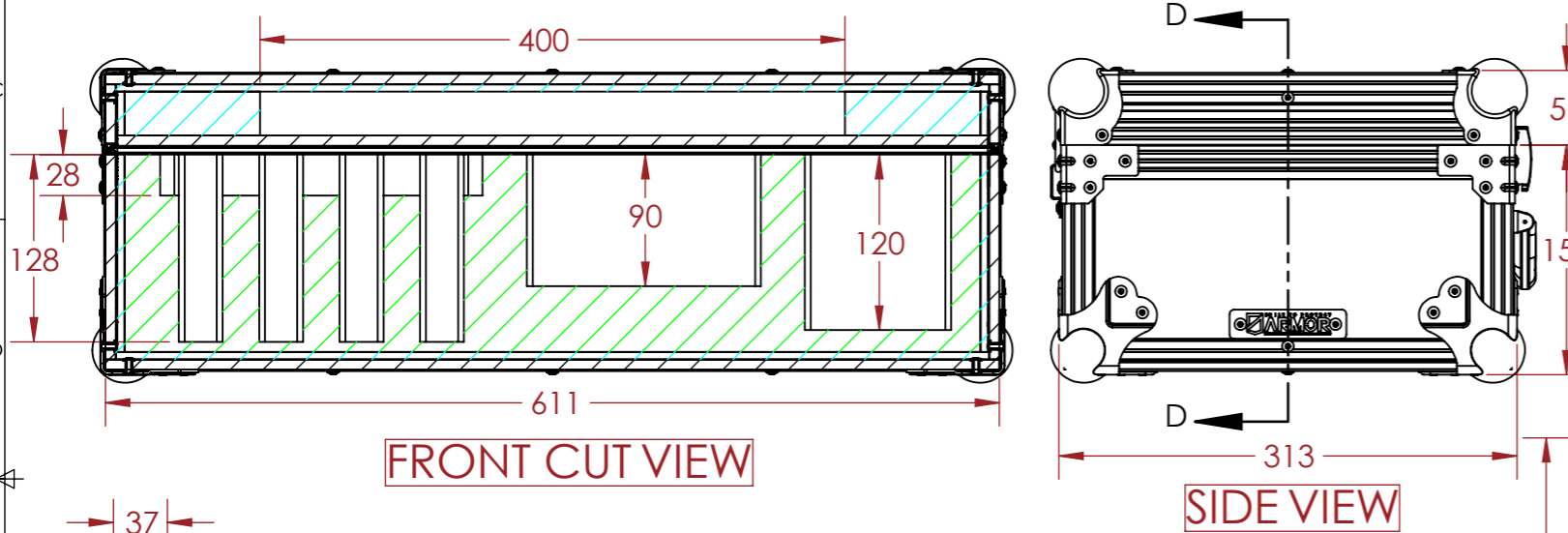
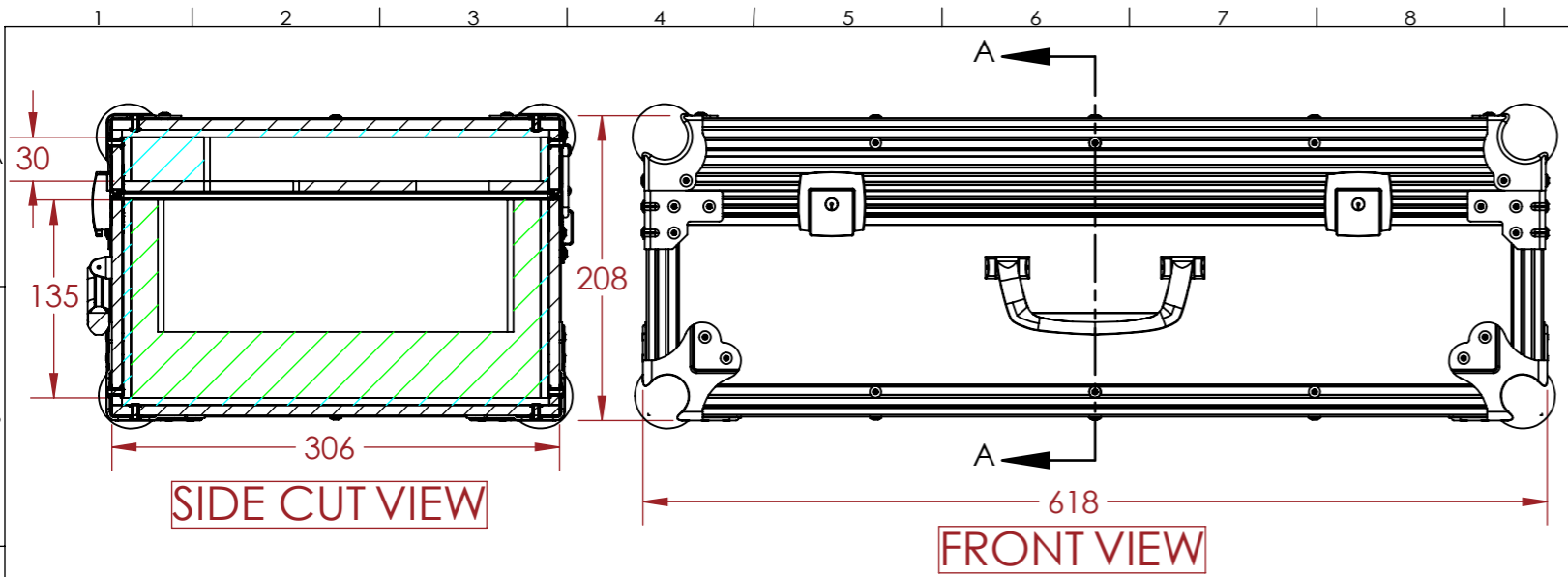

ITEM NO.	DESCRIPTION	PART NUMBER	QTY.
1	BRACES	B4204C	4
2	CORNERS	C1992	4
3	CORNERS	Penn Elcom-1088	4
4	LATCHES	L0275	2
5	SURFACE HANDLE	H115	1
6	PLYWOOD PANEL 7mm	P701B	10
7	ANGLE EXTRUSION	E-SA30	16
8	EDGE EXTRUSION	EH7	8
9	HINGES	P1995	2

CUSTOMER: KARL STORZ	
DUE DATE:	
QUANTITY: 1	
PANEL FINISH: P701B	
HARDWARE: MATT	
DRAWING: D-CMAC-N4_X8	
DRAWN BY: DS	CHECKED BY: AS
SCALE: 1:5	REVISION: 0

ARMOR
 BUILT TO PROTECT

ADD : 45/7-9 Percy St,Auburn,
 NSW 2144, Australia
 PH : 02 9188 6801
 MAIL : sales@armorcases.com.au
 WEB : www.armorcases.com.au