

TOP VIEW

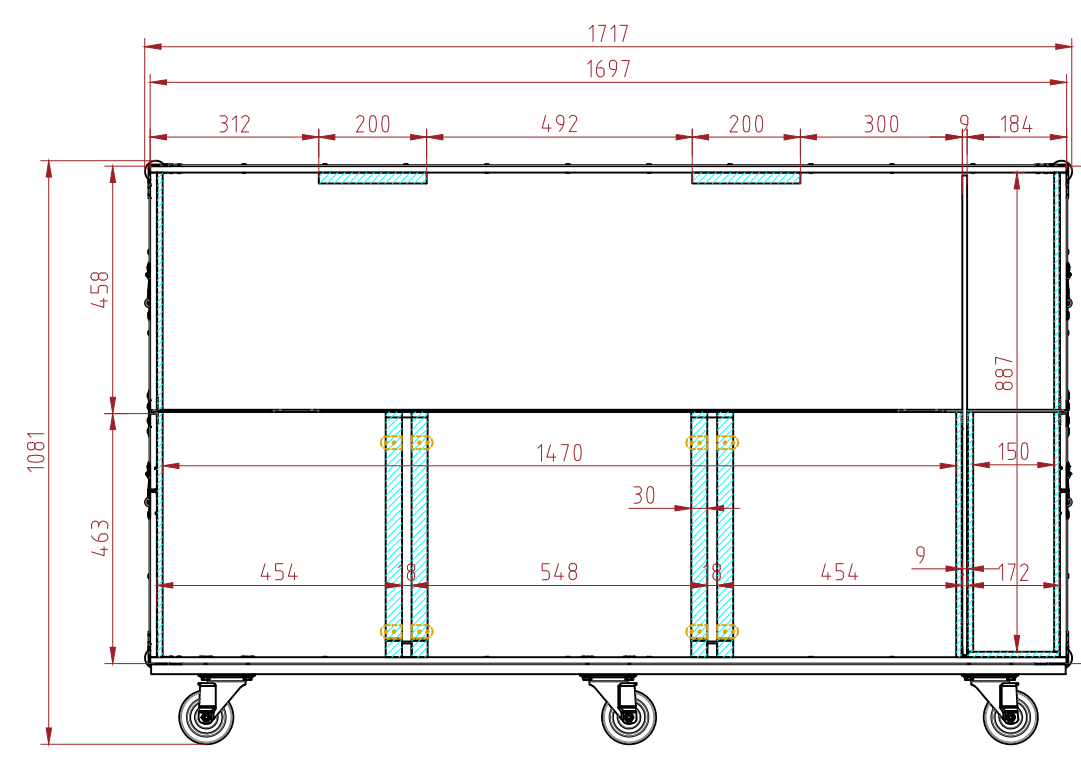

FRONT VIEW

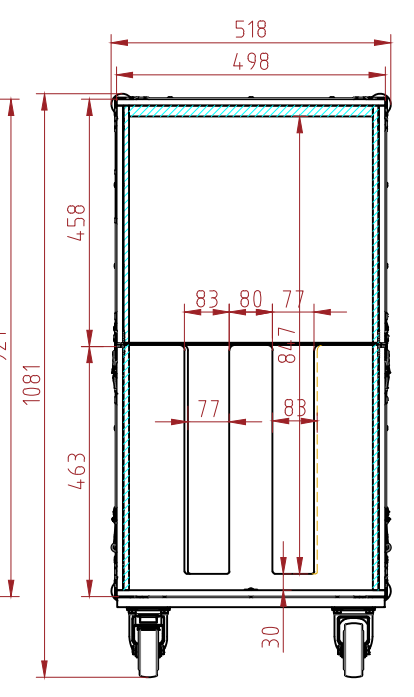

SIDE VIEW

 EVA FOAM

ITEM NO.	DESCRIPTION	PART NUMBER	QTY.
1	BRACES	YR-4501M	8
2	BRACES	YR-4602	20
3	BALL CORNERS	SY-B35	8
4	LATCHES	L944-527-10MOL3	4
5	RECESSED HANDLE	H1101M	12
6	PLYWOOD PANEL 9mm	P904	1
7	PLYWOOD PANEL 12mm	P1202	10
8	SINGLE ANGLE EXTRUSION	E-SA35	12
9	EDGE EXTRUSION	EH12	8
10	U-CAP EXTRUSION	E-U9	3
11	LABEL DISH	D2116	1
12	CASTOR	CARJET S2 100mm SWIVEL	3
13	CASTOR	CARJET S2 100mm SWIVEL WITH BRAKE	3

NOTES:
LEFT AND RIGHT TV DIVIDER PANELS AND FOAM OPENINGS ARE NOT SYMMETRIC, PLEASE REFER TO TOP VIEW FOR REFERENCE

CUSTOMER:	
DUE DATE:	
QUANTITY:	1
PANEL FINISH:	1202
HARDWARE:	MATT
DRAWING:	TV-PS-65SQE1W-2 Case
DRAWN BY:	RP
CHECKED BY:	AS
SCALE:	1:14
REVISION:	0



ADD: 45/7-9 Percy St, Auburn,
NSW 2144, Australia
PH: 02 9188 6801
MAIL: sales@armorcases.com.au
WEB: www.armorcases.com.au