

EXTRA FOAM

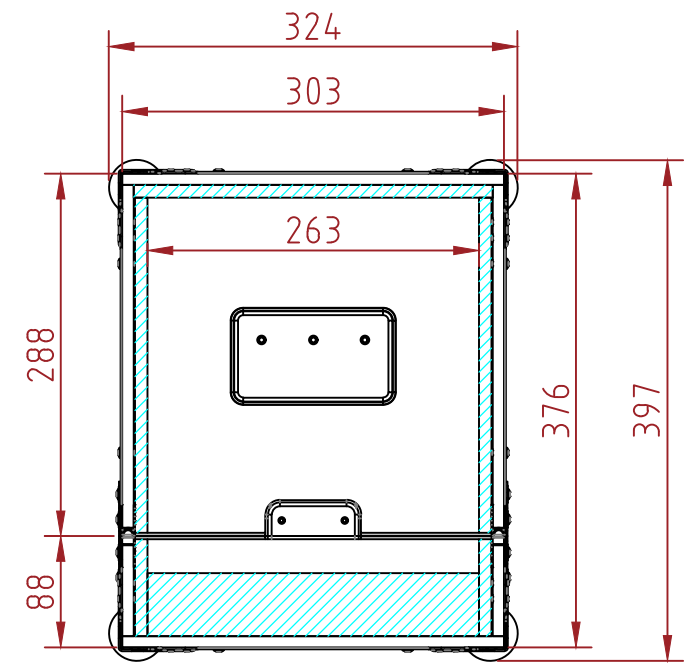
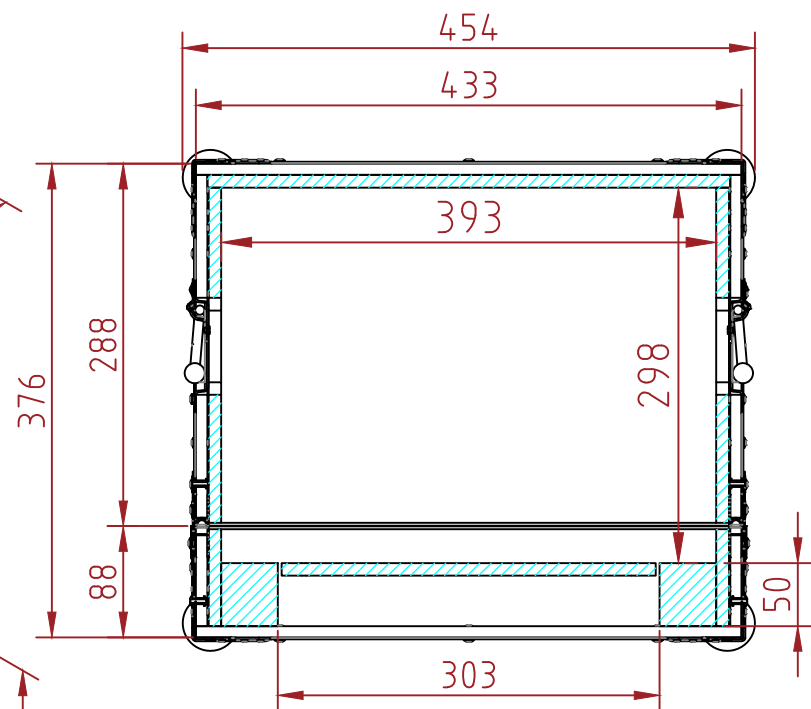

 EVA FOAMS

| ITEM NO. | DESCRIPTION | PART NUMBER | QTY. |
|----------|------------------------|-------------|------|
| 1 | BRACES | YR-4501 | 8 |
| 2 | CORNERS | C3102 | 8 |
| 3 | LATCHES | L2208 | 2 |
| 4 | SURFACE HANDLE | H1101 | 2 |
| 5 | PLYWOOD PANEL 9mm | P910 | 10 |
| 6 | SINGLE ANGLE EXTRUSION | E-SA30 | 16 |
| 7 | EDGE EXTRUSION | E-E25-T9 | 2 |
| 8 | EDGE EXTRUSION | E-E25-G9 | 2 |

NOTES:

CUSTOMER:

DUE DATE:

QUANTITY:
2

PANEL FINISH:
P910

HARDWARE:

DRAWING:
KH310A Case

DRAWN BY:
RP

CHECKED BY:
AS

SCALE:
1:6

REVISION:
0



ADD: 45/7-9 Percy St, Auburn,
NSW 2144, Australia
PH: 02 9188 6801
MAIL: sales@armorcases.com.au
WEB: www.armorcases.com.au