

10mmEVA lining for Lid

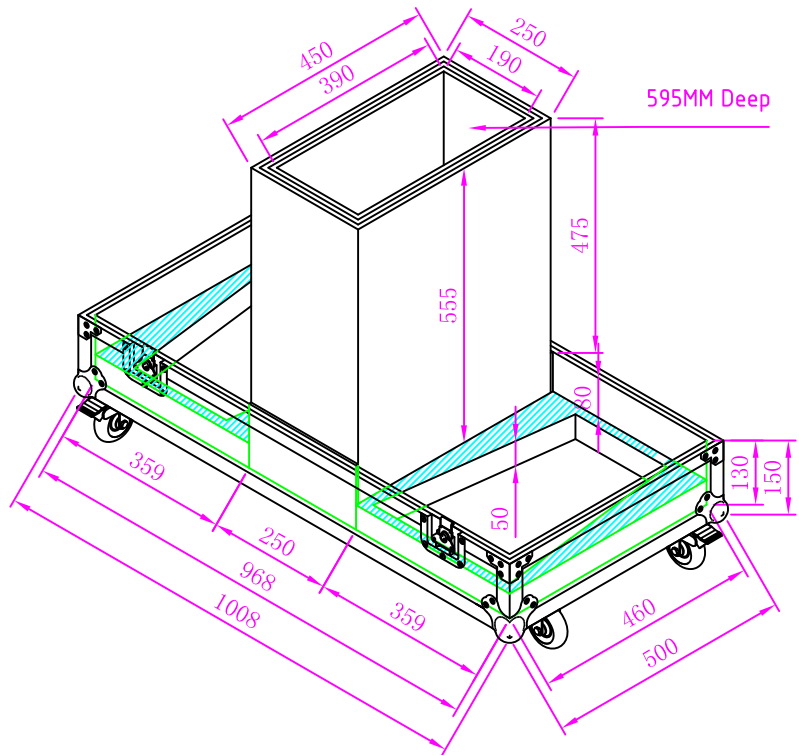
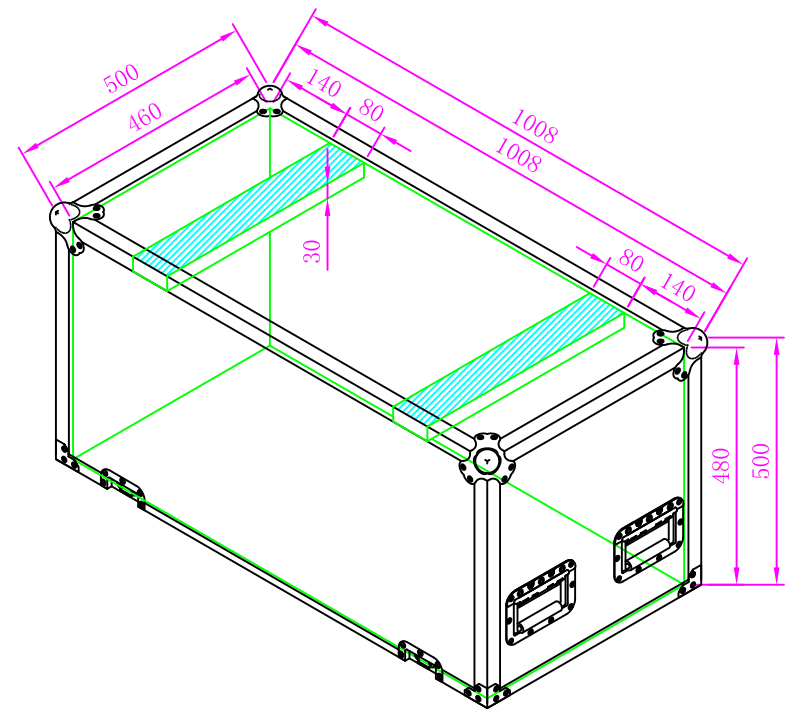

Order Quantity:

| Material Name                            | Model         | Qty.   |                       |
|--|---------------|--|-----------------------|
| 4" Castors                               |               | 4  |                       |
| Large Ball Corner 6 Hole                 |               | 8  |                       |
| Braces 6 Holes                           |               | 8  |                       |
| Medium Latch                             |               | 4  |                       |
| Medium Recessed Handle                   |               | 4  |                       |
| Extrusion 25mm High,1.5mm Thickness      | V2            | 8  |                       |
| Single Extrusion 30X30mm 1.5mm Thickness |               | 16   |                       |
| Plywood Black PVC Finish 9MM             |               | 1  |                       |
| Plywood Plain 9MM                        |               | 1  |                       |
| Itemref                                  | Quantity      | Title/Name, designation, material, dimension etc | Article No./Reference |
| Designed by JL                           | Checked by HH | Approved by - date AS - 25/03/2019               | Filename DB-Q10       |
|  |               |  | Date 25/03/2019       |
|  |               |  | Scale 1:1             |
| ARMOR ROAD CASES                         |               | DB-Q10   |                       |
|  |               | 190325A  | Edition V2 Sheet 1/1  |